



COMPLIANCE TRAINING
ONLINE.com

Cal/OSHA, DOT HAZMAT, EEOC, EPA, HIPAA, IATA, IMDG, TDG, MSHA, OSHA, Australia WHS, and Canada OHS Regulations and Safety Online Training

This document is provided as a training aid
and may not reflect current laws and regulations.

Be sure and consult with the appropriate governing agencies
or publication providers listed in the "Resources" section of our website.

www.ComplianceTrainingOnline.com



[Facebook](#)



[LinkedIn](#)



[Twitter](#)



[Google Plus](#)



[Website](#)

Solutions to prevent materials-handling injuries in underground coal mines

Introduction

Between June 1998 and the end of December 2002, 32,433 reportable accidents occurred in active underground coal mines in the United States (Fig. 1) (MSHA, 2002). The category "handling materials" accounted for 7,388 (22.8 percent) of these accidents and 244,365 days lost from work. Materials-handling tasks involve pulling, hanging, pushing and lifting objects of different weights, shapes and sizes. Hundreds of these tasks are performed in underground coal mines each day. Supplies are often handled two or three times before end use. Often, these tasks require supplies to be lifted above the shoulders and/or the body to be twisted during a lift, resulting in overexertion of back and other muscles. In addition, these tasks are often performed without assistance and by a person who may be fatigued. The materials-handling tasks that cause the most

Abstract

Of the 28 accident/injury classifications listed by the Mine Safety and Health Administration, handling materials is second only to roof falls in terms of generating the highest number of reportable accidents in active underground coal mines. Two materials-handling activities that cause numerous injuries each year are the categories of "handling supplies or material, load and unload" and "moving power cables." Mechanization and mineworker activity training are two methods that can aid in preventing these injuries. This paper describes three mechanical methods — the mobile manipulator, the in-mine hoist and a cable-handling system — that are being developed and tested at the Spokane Research Laboratory of the National Institute for Occupational Safety and Health. Two of the devices are specifically designed for loading, unloading and moving supplies and materials, and the third device is designed for handling trailing cables in the confined spaces of coal mines. Also described are safety solutions developed for underground coal mines geared towards showing miners safe and unsafe ways of performing various materials-handling tasks.¹

¹The findings and conclusions in this report are those of the authors and do not necessarily represent the views of the National Institute for Occupational Safety and Health.

B.M. STEWART, J.R. WARNEKE,
C.C. CLARK, B.P. STAPLETON

B.M. Stewart, J.R. Warneke, C.C. Clark and B.R. Stapleton are mining engineer (retired), associate research fellow, mechanical engineer and engineering technician, respectively, with the Spokane Research Laboratory, National Institute for Occupational Safety and Health (NIOSH), Spokane, Washington.

injuries involve loading and unloading supplies and materials, machine maintenance and repair and moving power cables (Fig. 2). For example, roof bolt operators may handle over 500 roof support items (bolts, resin, plates, mesh, etc.) in a single shift. Cable handling is another high-injury task; between 1997 and 2002, 1,138 reportable injuries and more than 43,000 lost work days involved the task "moving power cables."

Since December 1988, 23 fatalities were associated with remote-control continuous miners; at least nine of these fatalities were related to moving the trailing cable. Two fatalities (one in 2003 and one in 2004) occurred when the victim was manually moving power cable and a roof fall occurred.

Given the nature of underground coal mining environment (poor lighting, poor footing, confined spaces, etc.), the amount of supplies and equipment needed daily, the use of electrically powered equipment and the wide range of tasks, it is to be expected that materials handling will continue to be a major cause of injury. The purpose of this paper is to make underground miners aware of the risk of injury when handling materials and to offer solutions to avoid injury through innovative training and mechanical aids. Behavior modifications include the development of a series of articles on safety solutions and training materials that address common lifting tasks. Mechanical solutions include the mobile manipulator system and the in-mine hoist system, both of which can aid in lifting and moving heavy objects. A proposal for future research addressing the prevention of injuries associated with lifting and moving heavy power cables is presented.

Preventing materials-handling injuries

Behavior modification. Some miners do not think of handling materials as being a risky job, especially if the material is light and he or she has done the same task thousands of times without injury. However, while each person is equipped with excellent lifting parts (fingers, hands and arms) that are available on demand, the human body has limits, and over time injuries or fatal situations may occur. As Dr. John Snow once noted: "An occasional risk never stands in the way of ready availability." It is not until after an injury that a miner asks

FIGURE 1

Reportable accidents in active underground coal mines: 1998-2002.

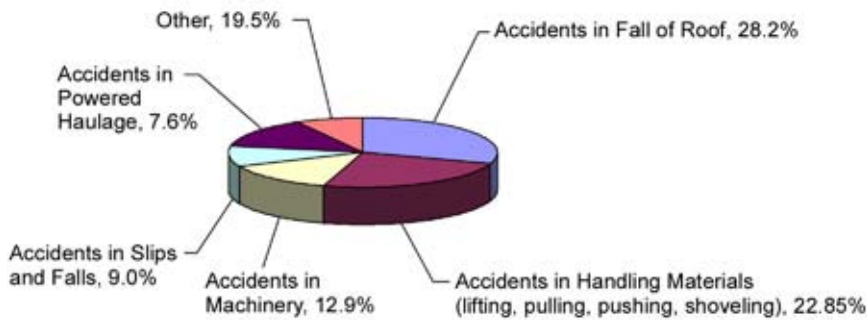
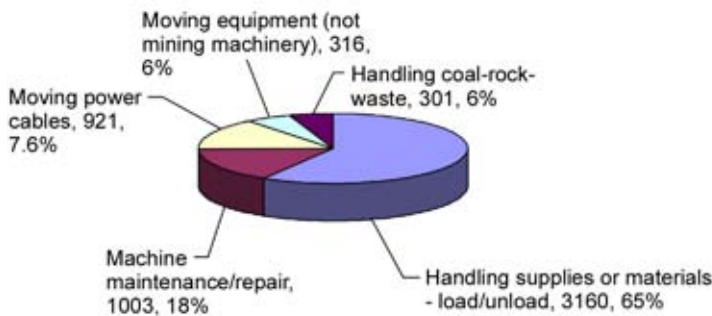

FIGURE 2

The five activities most responsible for materials-handling accidents in underground coal mines: 1998-2002.



"Why did this happen? Why didn't I get help? Why didn't I think of a safer way?"

To prevent materials-handling accidents and reduce injuries, behavior and attitude must be changed. First, a miner must be aware that lifting, pulling, pushing or shoveling — even the lightest load — can result in unnecessary injury. Second, the "think-before-you-lift" mindset needs to be in place before every materials-handling activity. Third, the materials handler must always ask: "Is there a safer way to move this object?" What this means is that prior to every materials-handling task, no matter how small, a person must ask essential questions such as: "How heavy is this object? Where is the object moving to? How far? Is the path clear? What are the safe lifting methods? Is there help (mechanical or personnel) available?" There is always a safe way to move an object. Knowing and using the safest way will prevent injuries.

Safety solutions. The concept of safety solutions developed at the Spokane Research Laboratory (SRL) of the National Institute for Occupational Safety and Health (NIOSH) can aid miners in preventing materials-handling injuries. A safety solution is a two- or three-page article that describes an innovative method, procedure and/or equipment that was developed to reduce injuries and proven to be effective. The safety solution article includes a description of the problem, impact of the

problem, solution to the problem and impact of the solution. Whenever possible, photographs and drawings are included. Once the safety solution is developed, it is placed on the NIOSH mining Website. In this case, the goal is to prevent injuries by sharing and making mine operators aware of innovative solutions to common materials-handling problems.

Training. On-site training is an effective tool for the prevention of job-related injuries or deaths. SRL recently tested a concept to provide "expert knowledge" through the use of real miners working at an active mine to demonstrate right and wrong ways to perform a task or tasks. For the materials-handling task, two days were spent at an underground coal mine shooting video clips of miners performing various tasks that have had a high injury rate. These tasks included loading and unloading supply trailers and scoops (surface and underground), hanging power cables and ventilation tubing, cleaning around and shoveling materials onto moving conveyor belts, and moving conveyor belts. Figure 3 shows workers off-loading roof bolt supplies from a trailer to a scoop.

Mechanical solutions. A host of mining activities are performed in which materials or equipment must be lifted, positioned, held and or moved. Often, supply movement and distribution is not well planned, resulting in handling the same supplies two or three times before end use. Off-loading barriers are also created when the supplies needed first are at the bottom of the load. These barriers increase material handling risk factors. Assisted-lift devices are currently used in many industrial sectors to reduce injuries associated with manual equipment and materials handling. In most underground coal mines, getting needed materials from the surface to underground drop-off areas is done with trailers or supply cars that are loaded on the surface with forklifts or other mechanized devices. The materials are generally palletized and banded for this process. Once in a drop-off area, however, the materials are separated and must be moved manually by workers. For example, roof bolt supplies are often manually loaded from the trailer into a scoop and then unloaded a second time from the scoop to the roof bolter.

Mobile manipulator system: Loading and unloading supplies and materials cause the most injuries in the "handling materials" category. An industrial manipulator was obtained, and a series of typical lifting tasks were performed to determine the baseline performance of the device. Although it operated as intended with regard to lifting, several shortcomings were found regarding in-mine use. These included lack of mobility, instability, no self-leveling capability and excessive height and length.

FIGURE 3

Off-loading roof bolt supplies from a trailer to a scoop underground.



The manipulator was designed for use in medium to high coal areas and in areas where clearance is not a problem (e.g., shops, lay-down areas and station landings), but not in low coal areas.

Engineering solutions were pursued to address the functional limitations identified. An integrated design incorporating a manipulator, a self-propelled platform, independently controlled leveling stabilizers and an integral power supply was conceived and named the mobile manipulator system. This device was designed to reduce manual lifting tasks such as moving supplies from lay down areas, lifting supplies off trailers, loading roof-bolt pods and lifting construction materials. The mobile manipulator system is a highly mobile, compact, self-propelled lifting arm mounted on a turret. It has real-time leveling and stabilizing outriggers and a self-contained power and control system (Fig. 4).

This device provides a load-handling solution for those situations where a single worker may need to do a job quickly and might attempt to handle materials or equipment that are too heavy. Development of the system required extensive redesign of the original manipulator, as well as initial design of a self-propelled mobile platform. A device 810 mm (32 in.) wide, 1,620 mm (64 in.) long and 1,980 mm (78 in.) tall was determined to offer the widest range of applications. The specifications are provided in Fig. 5 and are discussed as follows:

- **Manipulator:** The manipulator configuration was extensively modified to fit the target dimensions of 810 by 1,620 by 1,980 mm (32 by 65 by 78 in.). The final manipulator configuration has a horizontal reach of 1,270 mm (50 in.) and a vertical reach of 1,040 mm (41 in.) and a lift capacity of 136 kg (300 lb). The device features a four-bar linkage system that allows mailbox-type insertion of materials and equipment not accessible from above.

- **Self-propelled platform:** The self-propelled platform is 1,610 mm (63.5 in.) long by 810 mm (32 in.) wide, with a wheelbase of 1,206 mm (47.5 in.) and a ground clearance of 76 mm (3 in.). Tram speed is either 0.8 or 3.2 km/h (0.5 or 2 mph). The unit consists of a 25-mm- (1-in.-) thick steel base plate to which four 406-mm- (16-in.-) diameter,

FIGURE 4

Design drawing of the mobile manipulator system.

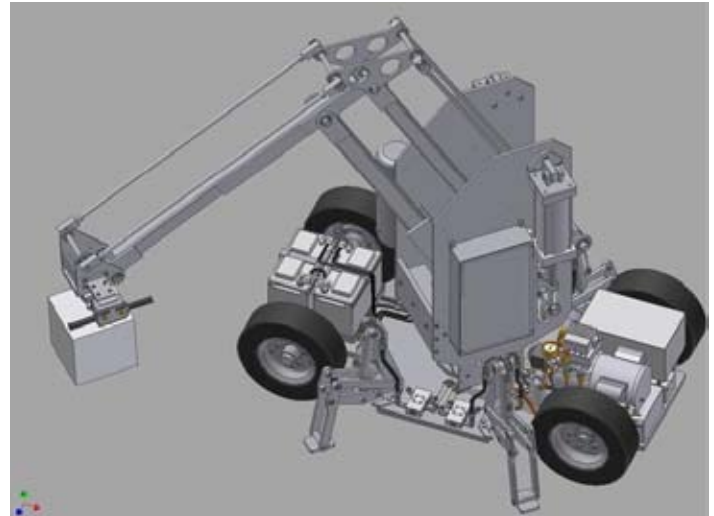

FIGURE 5

Specifications of the mobile manipulator system.

Specifications	
Vehicle	
Weight.....	3000 lbs
Length.....	63.5 in
Width-tram.....	32 in
Width-oper.....	44 in
Height-tram.....	78 in
Height-oper.....	97 in
Speed Slow.....	1/2 mph
Speed Fast.....	2 mph
Drive System.....	hydraulic
Gradability.....	25%
Manipulator	
Lifting Cap-hook.....	290 lbs
Vertical Reach.....	41 in
Horizontal Reach.....	50 in
Turret Rotation.....	360 deg
Operating Sys.....	pneumatic
Operating Pres.....	90 psi

foam-filled, hard-rubber-tired wheels are mounted. The front wheels are steered to the left or right via a hydraulic cylinder to a spindle tie rod-to-spindle arrangement. The left rear wheel is driven forward or reverse by a positive-displacement hydraulic drive motor.

- **Leveling stabilizers:** The leveling stabilizers consist of four independently controlled legs mounted on the mobile platform. The legs extend hydraulically in a scissoring motion when actuated to form a 1,118-mm- (44-in.-) wide by 965-mm- (38-in.-) long base and provide leveling for up to ± 76 mm (± 3 in.) of floor inclination. When retracted, the legs can be stowed within the 810-mm (32-in.) tram width of the manipulator. Extension of the legs and leveling control takes 15 sec.

- **Hydraulic power:** Hydraulic power is provided by a 24-V dc motor connected to a single, axially mounted, 15-L/min (4-gpm) pump. The pump drives the slow and fast tram speeds, steering and leveling stabilizers.

- **Pneumatic power:** Pneumatic power is provided by either shop air or a 120-V ac, 12.5-amp compressor unit with twin 7.6-L (2-gal) tanks that provides air at 0.136 m³/min (4.8-cu ft per min) at 690 kPa (100 psi).

FIGURE 6

Mobile manipulator system in final stages of fabrication.

The compressor system, in conjunction with the power supply, is capable of providing air for approximately 60 cycles ($0.028 \text{ m}^3/\text{min}$ [1 cu ft per min] per cycle) of the manipulator arm between charges. It is used for "tram-to-site" intermittent lifting. For fixed-location, high-repetition lifting, the manipulator is powered by shop air after it is put into position.

- *Electric power:* Electrical power is generated by two 12-V, deep-cycle, dc batteries connected in series. An interlock switch routes the 24-V dc power to the hydraulic system's 24-V dc motor and to a 24-V dc to 120-V ac inverter. Charging is via a 120-V ac charger integral to the inverter.

- *Controls:* The current control system consists of a tethered box that uses rubber-booted toggle switches to control all machine movements. Fabrication of the mobile manipulator system was recently completed (Fig. 6). Project personnel will conduct tests at SRL by operating the system in a manner consistent with what would be expected during mine-specific materials-handling and maintenance tasks. Detailed data sheets will be prepared for each activity as the basis of a series of trials. This information will also indicate the mobile manipulator's suitability for a mine environment.

In-mine hoist system. At defined material-handling locations or when the mechanized movement of supplies and materials down to a work area becomes impractical because of space limitations, power requirements or the unavailability of equipment, other means of moving materials is needed. A portable in-mine hoisting device was designed to be lightweight, easy to assemble, capable of carrying a payload up to 136 kg (300 lb) over a span of 12 m (40 ft) and not require any power source. The in-mine hoisting device can be readily set up to bridge the gap between the limits of where a mechanized lifting device can go and where the work needs to be done. The design incorporated the use of 3-m (10-ft) sections of 100-mm (4-in.) aluminum I-beams that functioned as a track for a 454-kg- (1,000-lb-) capacity hoist attached to a small trolley (Fig. 7). The I-beams were

FIGURE 7

In-mine hoist system attached to wire mesh.

connected with a locking system in which a steel pin on one end of the beam fits into a groove connector on the adjacent beam. A heavy-duty latch was used to secure the bottom portion of the two beams together. An additional steel plate was bolted on the web of the I-beams to provide additional stability and support (Fig. 8). The entire system was hung from wire mesh by a chain-and-roller system. Four 3-m (10-ft) sections of the in-mine hoisting device can be put together and hung from the ceiling of a mine by two workers in less than 20 min without any special tools.

After many trials and modifications, a 136-kg (300-lb) weight was lifted successfully and moved a distance of 12 m (40 ft). However, there are some limits as to how the in-mine hoisting device can be employed. These limits are as follows:

- When the 136-kg (300-lb) weight is moved from one end of the I-beam to the other, a significant amount of axial force is generated at the joints between each beam. The wire mesh holding the system then flexes under the payload as I-beam sections act as levers, which creates an axial force in excess of 6,230 N (1,400 lb/f). To overcome this axial force requires the use of heavy-duty steel connectors and latches to secure the beams together.

- The system also generates tremendous strain on the joint connectors whenever the device moves through a curved section, so that straight line movement is the only option.

- The chains supporting the system to the mine roof should be secure enough to offer less than 13 mm (0.5 in.) of flex to the overall system to ensure that the axial force remains under a more manageable 2,250 N (500 lb/f) while hauling the 136-kg (300-lb) payload.

Because of the limitations and flexing problems encountered when moving the load across I-beams hanging from wire mesh and because of safety concerns about placing additional loads on the primary roof support, tests are currently underway to test the feasibility of hanging the I-beams from roof bolts rather than wire mesh. Supplemental bolts outside the roof support plan

FIGURE 8

Locking system for aluminum joint sections on in-mine hoist.



would be used and the I-beams hung from scissor type hangers connected to the bolt heads. Although this approach will result in longer set-up times (supplemental bolt installation), it will be more stable and safe.

Some specific applications of the in-mine hoist system include off-loading supplies into scoops in crosscuts where supply trailers/cars are dropped off; moving supplies from the front of the lay down to the back (for storage) and vice versa (for use); moving/lifting blocks and timbers in construction areas; lifting pumps for repair or removal; and lifting and moving parts in underground machine shops.

Directions for future materials-handling research

On April 29, 2004, the Mine Safety and Health Administration (MSHA) held a workshop to address problems in handling the trailing cables on continuous miners. From that workshop, three ideas came to the forefront: wireless communication for workers at the face, remote-control shut down (multiple e-stops) for miners working around the machine and cable reels.

The Materials Handling Group at SRL did additional research on cable handling injuries and generated the following statistics:

- Currently, there are about 620 continuous-mining machines operated by remote control in underground coal mines in the United States (MSHA, 2004a).
- From December 1988 to December 2003, 21 fatalities have been associated with the operation, assistance and maintenance of remote-controlled continuous miners (MSHA, 2003). Between March 1995 and March 2004, nine fatal accidents occurred among people either handling or watching the cable on a remote-controlled continuous miner (Gandy, 2004). Five fatalities occurred when the operator or assistant was crushed while manually moving or positioning the cable.
- During the five-year period between 1998 and 2002, moving power cables in active underground coal mines was the cause of 921 injuries. The words “miner cable” (short for continuous miner cable) appeared in the descriptions of 497 (54 percent) of these injuries. In looking at the most recent statistics (for 2002), 149 entries

FIGURE 9

Artist’s concept of off-machine cable reel system.

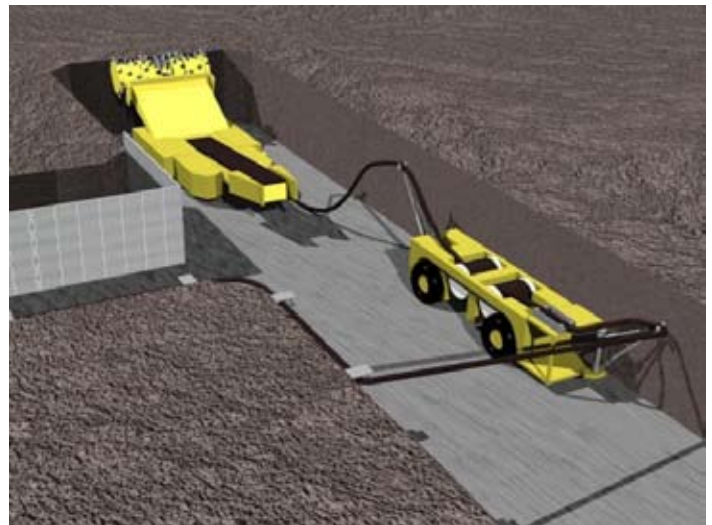

were moving power cable injuries with 8,114 days lost from work.

Based on 2004 MSHA data (MSHA, 2004b) and on the workshop, the Materials Handling Group decided to take an in-depth look at a concept of cable reels as an aid to automating the cable-handling task. This project will look at a total cable management system consisting of the following two parts:

- *Part 1:* The problem of manually moving that portion of trailing cable lying on the ground between the continuous miner and the point where the cable is hung from the roof or rib will be addressed. The goal is to devise an automated handling system that will keep the operator (or operator assistant) and the cable clear of the continuous miner as it moves forward and backward. Figure 9 is an artist’s concept of a cable reel drawn in the 1970s for the U.S. Bureau of Mines on contract with FMC Corp. This reel system was never fabricated. The configuration of a continuous miner prevents a cable reel from being mounted on the miner itself, as is available on other mining machines. The system will have to be capable of advancing as the continuous miner advances. If successful, this system will remove miners from a dangerous location and the cable can be moved remotely.
- *Part 2:* The second part of the project will address-mechanical methods to hang and remove cable from the roof. This is currently done manually. Figure 10 shows a miner in an underground coal mine hanging a cable from the roof (a cause of many of the reported injuries).

Most of the technical aspects of the cable management problem have been solved, including heating of the cable, cable bending radius and cable hangers. The development of a system that will take miners out of harm’s way should become a critical goal. It is now time that stakeholders, who include organized labor, mining companies and government, make solving cable-handling problems a key concern. Once these problems of cable handling have been solved, a major safety issue will have been resolved in underground coal mining.

FIGURE 10

Miner manually hanging cable from mine roof.



Conclusions

Hundreds of materials-handling tasks are performed in underground mines each day. It would be hard to find one of these tasks that has not resulted in an injury at least once. Materials-handling innovations and research efforts have paid off, considering that the number of materials-handling injuries has been reduced by over 60 percent in the last 10 years. However, materials handling continues to be one of the MSHA category with the highest percentages of accidents and injuries in underground mines. Additional research efforts are warranted and must continue. Some solutions are simple, such as reducing “package” weight. Other solutions are not so simple, such as hanging objects overhead and moving trailing cables. Whether simple or complex, the solutions must be practical to be accepted and used. Because of the diversity of materials-handling tasks, no single solution exists to eliminate materials-handling injuries.

Research and development of mechanized materials-handling tools and equipment need to continue with an emphasis on those tasks that result in numerous injuries, such as loading and unloading supplies, machine repair, moving power cables, moving roof bolt supplies, handling and shoveling coal and waste rock, and moving conveyor belt parts. One of the best sources for identifying materials-handling mechanization needs is the miners who daily handle the supplies and materials. Managers need

to listen to their needs and then supply the resources to make their jobs safer.

It is neither technically or economically feasible to mechanize all underground materials-handling tasks. Some tasks need to be done manually. However, injuries can be minimized if mandatory site materials-handling safety criteria are established. The criteria would be designed by the safety manager as per injury records, task location, type of task and other factors. However, mandatory materials-handling criteria are useless unless the individual performing the task follows them. It is up to the individual to think about every lifting action prior to doing it. Unfortunately, many people have to experience the pain of a serious injury before they learn this. There is always a better, easier, less injurious way to handle materials. Even if the lifting job is delayed while waiting for proper help or equipment, it is better for the individual and the company than a long-term back injury. Management at all levels should mandate smart, risk-free materials handling with a “take time to do it right” attitude.

Materials handling should be an integral part of every safety and training meeting. Any materials-handling task that increases risk factors should be a warning sign for injury. Mine safety officers should identify those tasks that cause frequent injuries at their mine and conduct specialized materials handling safety training with individuals performing these tasks. Such training would be valuable for new miners because they frequently get jobs involving supplies and materials handling. Constant (daily) safe materials-handling reminders from safety managers and shift foremen will aid in getting miners into the habit of not only “thinking before they lift,” but also thinking before they carry, pull, hang, or push supplies and materials.

References

- Gandy, B.. 2004, Engineer, MSHA, personal communication.
- Mine Safety and Health Administration (MSHA), 2002. “Accident, Illness, and Injury and Employment Self-Extracting Files,” available at www.MSHA.gov.
- Mine Safety and Health Administration (MSHA). 2003, “Remote Control Fatal Accident Analysis Report of Victim’s Physical Location with Respect to the Mining Machine,” prepared by J. Dransite and C. Huntley.
- Mine Safety and Health Administration (MSHA), 2004a, Author notes from Webcast on remote-controlled continuous miner fatalities, January 28.
- Mine Safety and Health Administration (MSHA), 2004b, “Summary Report of the Cable-Handling Workshop,” Staff, Applied Engineering Division, MSHA.