



COMPLIANCE TRAINING
ONLINE.com

Cal/OSHA, DOT HAZMAT, EEOC, EPA, HIPAA, IATA, IMDG, TDG, MSHA, OSHA, Australia WHS, and Canada OHS Regulations and Safety Online Training

This document is provided as a training aid
and may not reflect current laws and regulations.

Be sure and consult with the appropriate governing agencies
or publication providers listed in the "Resources" section of our website.

www.ComplianceTrainingOnline.com



[Facebook](#)



[LinkedIn](#)



[Twitter](#)



[Google Plus](#)



[Website](#)

Subpart D – Walking-Working Surfaces

§1910.21 Scope and definitions.

(a) Scope. This subpart applies to all general industry workplaces. It covers all walking-working surfaces unless specifically excluded by an individual section of this subpart.

(b) Definitions. The following definitions apply in this subpart:

Alternating tread-type stair means a type of stairway consisting of a series of treads that usually are attached to a center support in an alternating manner such that an employee typically does not have both feet on the same level while using the stairway.

Anchorage means a secure point of attachment for equipment such as lifelines, lanyards, deceleration devices, and rope descent systems.

Authorized means an employee who the employer assigns to perform a specific type of duty, or allows in a specific location or area.

Cage means an enclosure mounted on the side rails of a fixed ladder or fastened to a structure behind the fixed ladder that is designed to surround the climbing space of the ladder. A cage also is called a "cage guard" or "basket guard."

Carrier means the track of a ladder safety system that consists of a flexible cable or rigid rail attached to the fixed ladder or immediately adjacent to it.

Combination ladder means a portable ladder that can be used as a stepladder, extension ladder, trestle ladder, or stairway ladder. The components of a combination ladder also may be used separately as a single ladder.

Dangerous equipment means equipment, such as vats, tanks, electrical equipment, machinery, equipment or machinery with protruding parts, or other similar units, that, because of their function or form, may harm an employee who falls into or onto the equipment.

Designated area means a distinct portion of a walking-working surface delineated by a warning line in which employees may perform work without additional fall protection.

Dockboard means a portable or fixed device that spans a gap or compensates for a difference in elevation between a loading platform and a transport vehicle. Dockboards include, but are not limited to, bridge plates, dock plates, and dock levelers.

Equivalent means alternative designs, equipment, materials, or methods, that the employer can demonstrate will provide an equal or greater degree of safety for employees compared to the designs, equipment, materials, or methods specified in this subpart.

Extension ladder means a non-self-supporting portable ladder that is adjustable in length.

Failure means a load refusal, breakage, or separation of component parts. A load refusal is the point at which the ultimate strength of a component or object is exceeded.

Fall hazard means any condition on a walking-working surface that exposes an employee to a risk of harm from a fall on the same level or to a lower level.

Fall protection means any equipment, device, or system that prevents an employee from falling from an elevation or mitigates the effect of such a fall.

Fixed ladder means a ladder with rails or individual rungs that is permanently attached to a structure, building, or equipment. Fixed ladders include individual-rung ladders, but not ship stairs, step bolts, or manhole steps.

Grab bar means an individual horizontal or vertical handhold installed to provide access above the height of the ladder.

Guardrail system means a barrier erected along an unprotected or exposed side, edge, or other area of a walking-working surface to prevent employees from falling to a lower level.

Handrail means a rail used to provide employees with a handhold for support.

Hoist area means any elevated access opening to a walking-working surface through which equipment or materials are loaded or received.

Hole means a gap or open space in a floor, roof, horizontal walking-working surface, or similar surface that is at least 2 inches (5 cm) in its least dimension.

Individual-rung ladder means a ladder that has rungs individually attached to a building or structure. An individual-rung ladder does not include manhole steps.

Ladder means a device with rungs, steps, or cleats used to gain access to a different elevation.

Ladder safety system means a system designed to eliminate or reduce the possibility of falling from a ladder. A ladder safety system usually consists of a carrier, safety sleeve, lanyard, connectors, and body harness. Cages and wells are not ladder safety systems.

Low-slope roof means a roof that has a slope less than or equal to a ratio of 4 in 12 (vertical to horizontal).

Lower level means a surface or area to which an employee could fall. Such surfaces or areas include, but are not limited to, ground levels, floors, roofs, ramps, runways, excavations, pits, tanks, materials, water, equipment, and similar surfaces and structures, or portions thereof.

Manhole steps means steps that are individually attached to, or set into, the wall of a manhole structure.

Maximum intended load means the total load (weight and force) of all employees, equipment, vehicles, tools, materials, and other loads the employer reasonably anticipates to be applied to a walking-working surface at any one time.

Mobile means manually propelled or moveable.

Mobile ladder stand (ladder stand) means a mobile, fixed-height, self-supporting ladder

that usually consists of wheels or casters on a rigid base and steps leading to a top step. A mobile ladder stand also may have handrails and is designed for use by one employee at a time.

Mobile ladder stand platform means a mobile, fixed-height, self-supporting unit having one or more standing platforms that are provided with means of access or egress.

Open riser means the gap or space between treads of stairways that do not have upright or inclined members (risers).

Opening means a gap or open space in a wall, partition, vertical walking-working surface, or similar surface that is at least 30 inches (76 cm) high and at least 18 inches (46 cm) wide, through which an employee can fall to a lower level.

Personal fall arrest system means a system used to arrest an employee in a fall from a walking-working surface. It consists of a body harness, anchorage, and connector. The means of connection may include a lanyard, deceleration device, lifeline, or a suitable combination of these.

Personal fall protection system means a system (including all components) an employer uses to provide protection from falling or to safely arrest an employee's fall if one occurs. Examples of personal fall protection systems include personal fall arrest systems, positioning systems, and travel restraint systems.

Platform means a walking-working surface that is elevated above the surrounding area.

Portable ladder means a ladder that can readily be moved or carried, and usually consists of side rails joined at intervals by steps, rungs, or cleats.

Positioning system (work-positioning system) means a system of equipment and connectors that, when used with a body harness or body belt, allows an employee to be supported on an elevated vertical surface, such as a wall or window sill, and work with both hands free.

Positioning systems also are called “positioning system devices” and “work-positioning equipment.”

Qualified describes a person who, by possession of a recognized degree, certificate, or professional standing, or who by extensive knowledge, training, and experience has successfully demonstrated the ability to solve or resolve problems relating to the subject matter, the work, or the project.

Ramp means an inclined walking-working surface used to access another level.

Riser means the upright (vertical) or inclined member of a stair that is located at the back of a stair tread or platform and connects close to the front edge of the next higher tread, platform, or landing.

Rope descent system means a suspension system that allows an employee to descend in a controlled manner and, as needed, stop at any point during the descent. A rope descent system usually consists of a roof anchorage, support rope, a descent device, carabiner(s) or shackle(s), and a chair (seatboard). A rope descent system also is called controlled descent equipment or apparatus. Rope descent systems do not include industrial rope access systems.

Rung, step, or cleat means the cross-piece of a ladder on which an employee steps to climb up and down.

Runway means an elevated walking-working surface, such as a catwalk, a foot walk along shafting, or an elevated walkway between buildings.

Scaffold means any temporary elevated or suspended platform and its supporting structure, including anchorage points, used to support employees, equipment, materials, and other items. For purposes of this subpart, a scaffold does not include a crane-suspended or derrick-suspended personnel platform or a rope descent system.

Ship stair (ship ladder) means a stairway that is equipped with treads, stair rails, and open risers, and has a slope that is between 50 and 70 degrees from the horizontal.

Side-step ladder means a type of fixed ladder that requires an employee to step sideways from it in order to reach a walking-working surface, such as a landing.

Spiral stairs means a series of treads attached to a vertical pole in a winding fashion, usually within a cylindrical space.

Stair rail or stair rail system means a barrier erected along the exposed or open side of stairways to prevent employees from falling to a lower level.

Stairway (stairs) means risers and treads that connect one level with another, and includes any landings and platforms in between those levels. Stairways include standard, spiral, alternating tread-type, and ship stairs.

Standard stairs means a fixed or permanently installed stairway. Ship, spiral, and alternating tread-type stairs are not considered standard stairs.

Step bolt (pole step) means a bolt or rung attached at intervals along a structural member used for foot placement and as a handhold when climbing or standing.

Stepladder means a self-supporting, portable ladder that has a fixed height, flat steps, and a hinged back.

Stepstool means a self-supporting, portable ladder that has flat steps and side rails. For purposes of the final rule, stepstool includes only those ladders that have a fixed height, do not have a pail shelf, and do not exceed 32 inches (81 cm) in overall height to the top cap, although side rails may extend above the top cap. A stepstool is designed so an employee can climb and stand on all of the steps and the top cap.

Through ladder means a type of fixed ladder that allows the employee to step through the

side rails at the top of the ladder to reach a walking-working surface, such as a landing.

Tieback means an attachment between an anchorage (e.g., structural member) and a supporting device (e.g., parapet clamp or cornice hook).

Toeboard means a low protective barrier that is designed to prevent materials, tools, and equipment from falling to a lower level, and protect employees from falling.

Travel restraint system means a combination of an anchorage, anchorage connector, lanyard (or other means of connection), and body support that an employer uses to eliminate the possibility of an employee going over the edge of a walking-working surface.

Tread means a horizontal member of a stair or stairway, but does not include landings or platforms.

Unprotected sides and edges mean any side or edge of a walking-working surface (except at entrances and other points of access) where there is no wall, guardrail system, or stair rail system to protect an employee from falling to a lower level.

Walking-working surface means any horizontal or vertical surface on or through which an employee walks, works, or gains access to a work area or workplace location.

Warning line means a barrier erected to warn employees that they are approaching an unprotected side or edge, and which designates an area in which work may take place without the use of other means of fall protection.

Well means a permanent, complete enclosure around a fixed ladder.

§1910.22 General requirements.

(a) Surface conditions. The employer must ensure:

(1) All places of employment, passageways, storerooms, service rooms, and walking-working surfaces are kept in a clean, orderly, and sanitary condition.

(2) The floor of each workroom is maintained in a clean and, to the extent feasible, in a dry condition. When wet processes are used, drainage must be maintained and, to the extent feasible, dry standing places, such as false floors, platforms, and mats must be provided.

(3) Walking-working surfaces are maintained free of hazards such as sharp or protruding objects, loose boards, corrosion, leaks, spills, snow, and ice.

(b) Loads. The employer must ensure that each walking-working surface can support the maximum intended load for that surface.

(c) Access and egress. The employer must provide, and ensure each employee uses, a safe means of access and egress to and from walking-working surfaces.

(d) Inspection, maintenance, and repair. The employer must ensure:

(1) Walking-working surfaces are inspected, regularly and as necessary, and maintained in a safe condition;

(2) Hazardous conditions on walking-working surfaces are corrected or repaired before an employee uses the walking-working surface again. If the correction or repair cannot be made immediately, the hazard must be guarded to prevent employees from using the walking-working surface until the hazard is corrected or repaired; and

(3) When any correction or repair involves the structural integrity of the walking-working surface, a qualified person performs or supervises the correction or repair.

§1910.23 Ladders.

(a) Application. The employer must ensure that each ladder used meets the requirements of this section. This section covers all ladders, except when the ladder is:

(1) Used in emergency operations such as firefighting, rescue, and tactical law enforcement operations, or training for these operations; or

(2) Designed into or is an integral part of machines or equipment.

(b) General requirements for all ladders. The employer must ensure:

(1) Ladder rungs, steps, and cleats are parallel, level, and uniformly spaced when the ladder is in position for use;

(2) Ladder rungs, steps, and cleats are spaced not less than 10 inches (25 cm) and not more than 14 inches (36 cm) apart, as measured between the centerlines of the rungs, cleats, and steps, except that:

(i) Ladder rungs and steps in elevator shafts must be spaced not less than 6 inches (15 cm) apart and not more than 16.5 inches (42 cm) apart, as measured along the ladder side rails; and

(ii) Fixed ladder rungs and steps on telecommunication towers must be spaced not more than 18 inches (46 cm) apart, measured between the centerlines of the rungs or steps;

(3) Steps on stepstools are spaced not less than 8 inches (20 cm) apart and not more than 12 inches (30 cm) apart, as measured between the centerlines of the steps;

(4) Ladder rungs, steps, and cleats have a minimum clear width of 11.5 inches (29 cm) on portable ladders and 16 inches (41 cm) (measured before installation of ladder safety systems) for fixed ladders, except that:

(i) The minimum clear width does not apply to ladders with narrow rungs that are not designed to be stepped on, such as those located on the tapered end of orchard ladders and similar ladders;

(ii) Rungs and steps of manhole entry ladders that are supported by the manhole opening must have a minimum clear width of 9 inches (23 cm);

(iii) Rungs and steps on rolling ladders used in telecommunication centers must have a

minimum clear width of 8 inches (20 cm); and

(iv) Stepstools have a minimum clear width of 10.5 inches (26.7 cm);

(5) Wooden ladders are not coated with any material that may obscure structural defects;

(6) Metal ladders are made with corrosion-resistant material or protected against corrosion;

(7) Ladder surfaces are free of puncture and laceration hazards;

(8) Ladders are used only for the purposes for which they were designed;

(9) Ladders are inspected before initial use in each work shift, and more frequently as necessary, to identify any visible defects that could cause employee injury;

(10) Any ladder with structural or other defects is immediately tagged “Dangerous: Do Not Use” or with similar language in accordance with §1910.145 and removed from service until repaired in accordance with §1910.22(d), or replaced;

(11) Each employee faces the ladder when climbing up or down it;

(12) Each employee uses at least one hand to grasp the ladder when climbing up and down it; and

(13) No employee carries any object or load that could cause the employee to lose balance and fall while climbing up or down the ladder.

(c) Portable ladders. The employer must ensure:

(1) Rungs and steps of portable metal ladders are corrugated, knurled, dimpled, coated with skid-resistant material, or otherwise treated to minimize the possibility of slipping;

(2) Each stepladder or combination ladder used in a stepladder mode is equipped with a metal spreader or locking device that securely holds the front and back sections in an open position while the ladder is in use;

(3) Ladders are not loaded beyond the maximum intended load;

Note to paragraph (c)(3): The maximum intended load, as defined in §1910.21(b), includes the total load (weight and force) of the employee and all tools, equipment, and materials being carried.

(4) Ladders are used only on stable and level surfaces unless they are secured or stabilized to prevent accidental displacement;

(5) No portable single rail ladders are used;

(6) No ladder is moved, shifted, or extended while an employee is on it;

(7) Ladders placed in locations such as passageways, doorways, or driveways where they can be displaced by other activities or traffic:

(i) Are secured to prevent accidental displacement; or

(ii) Are guarded by a temporary barricade, such as a row of traffic cones or caution tape, to keep the activities or traffic away from the ladder;

(8) The cap (if equipped) and top step of a stepladder are not used as steps;

(9) Portable ladders used on slippery surfaces are secured and stabilized;

(10) The top of a non-self-supporting ladder is placed so that both side rails are supported, unless the ladder is equipped with a single support attachment;

(11) Portable ladders used to gain access to an upper landing surface have side rails that extend at least 3 feet (0.9 m) above the upper landing surface (see Figure D-1 of this section);

(12) Ladders and ladder sections are not tied or fastened together to provide added length unless they are specifically designed for such use;

(13) Ladders are not placed on boxes, barrels, or other unstable bases to obtain additional height.

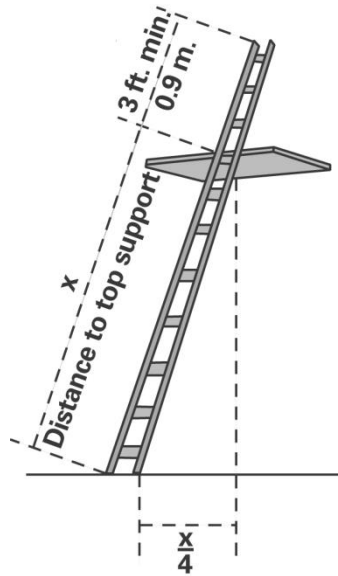

Figure D-1 -- Portable Ladder Set-up

(d) Fixed ladders. The employer must ensure:

- (1) Fixed ladders are capable of supporting their maximum intended load;
- (2) The minimum perpendicular distance from the centerline of the steps or rungs, or grab bars, or both, to the nearest permanent object in back of the ladder is 7 inches (18 cm), except for elevator pit ladders, which have a minimum perpendicular distance of 4.5 inches (11 cm);
- (3) Grab bars do not protrude on the climbing side beyond the rungs of the ladder that they serve;
- (4) The side rails of through or side-step ladders extend 42 inches (1.1 m) above the top of the access level or landing platform served by the ladder. For parapet ladders, the access level is:
 - (i) The roof, if the parapet is cut to permit passage through the parapet; or
 - (ii) The top of the parapet, if the parapet is continuous;
- (5) For through ladders, the steps or rungs are omitted from the extensions, and the side rails are flared to provide not less than 24 inches (61cm) and not more than 30 inches (76 cm) of

clearance. When a ladder safety system is provided, the maximum clearance between side rails of the extension must not exceed 36 inches (91 cm);

(6) For side-step ladders, the side rails, rungs, and steps must be continuous in the extension (see Figure D-2 of this section);

(7) Grab bars extend 42 inches (1.1 m) above the access level or landing platforms served by the ladder;

(8) The minimum size (cross-section) of grab bars is the same size as the rungs of the ladder.

(9) When a fixed ladder terminates at a hatch (see Figure D-3 of this section), the hatch cover:

(i) Opens with sufficient clearance to provide easy access to or from the ladder; and

(ii) Opens at least 70 degrees from horizontal if the hatch is counterbalanced;

(10) Individual-rung ladders are constructed to prevent the employee's feet from sliding off the ends of the rungs (see Figure D-4 of this section);

(11) Fixed ladders having a pitch greater than 90 degrees from the horizontal are not used;

(12) The step-across distance from the centerline of the rungs or steps is:

(i) For through ladders, not less than 7 inches (18 cm) and not more than 12 inches (30 cm) to the nearest edge of the structure, building, or equipment accessed from the ladders;

(ii) For side-step ladders, not less than 15 inches (38 cm) and not more than 20 inches (51 cm) to the access points of the platform edge;

(13) Fixed ladders that do not have cages or wells have:

(i) A clear width of at least 15 inches (38 cm) on each side of the ladder centerline to the

nearest permanent object; and

(ii) A minimum perpendicular distance of 30 inches (76 cm) from the centerline of the steps or rungs to the nearest object on the climbing side. When unavoidable obstructions are encountered, the minimum clearance at the obstruction may be reduced to 24 inches (61 cm), provided deflector plates are installed (see Figure D-5 of this section).

Note to paragraph (d): Section 1910.28 establishes the employer's duty to provide fall protection for employees on fixed ladders, and §1910.29 specifies the criteria for fall protection systems for fixed ladders.

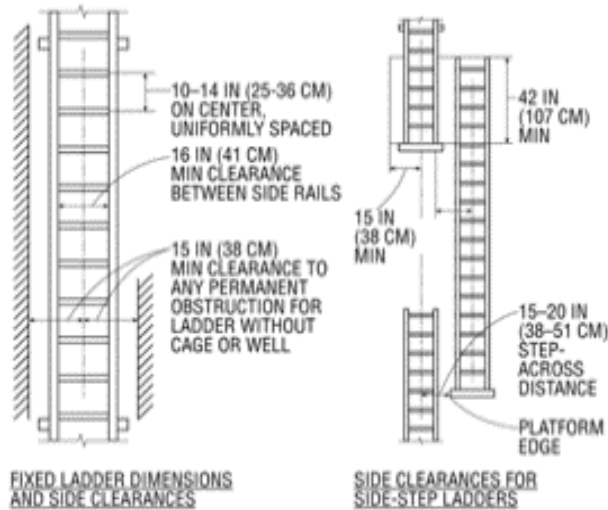

Figure D-2 -- Side-Step Fixed Ladder Sections

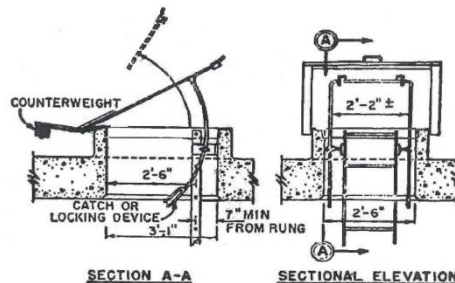

Figure D-3 – Example of Counterbalanced Hatch Cover at Roof

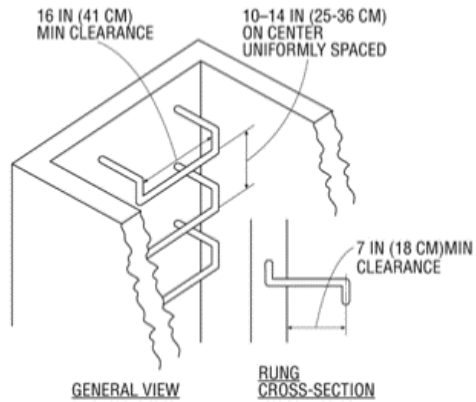

Figure D-4 -- Individual Rung Ladder

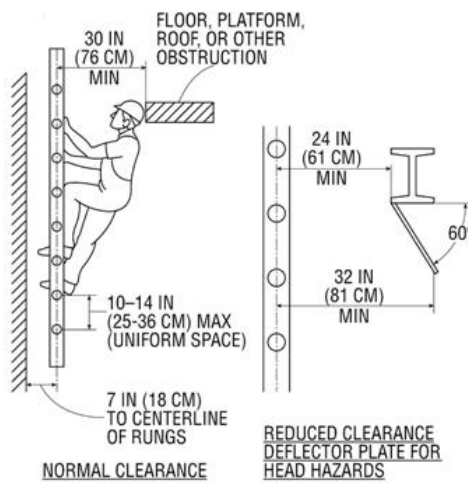

Figure D-5 -- Fixed Ladder Clearances

(e) Mobile ladder stands and mobile ladder stand platforms--(1) General requirements.

The employer must ensure:

- (i) Mobile ladder stands and platforms have a step width of at least 16 inches (41 cm);
- (ii) The steps and platforms of mobile ladder stands and platforms are slip resistant. Slip-resistant surfaces must be either an integral part of the design and construction of the mobile ladder stand and platform, or provided as a secondary process or operation, such as dimpling,

knurling, shotblasting, coating, spraying, or applying durable slip-resistant tapes;

(iii) Mobile ladder stands and platforms are capable of supporting at least four times their maximum intended load;

(iv) Wheels or casters under load are capable of supporting their proportional share of four times the maximum intended load, plus their proportional share of the unit's weight;

(v) Unless otherwise specified in this section, mobile ladder stands and platforms with a top step height of 4 feet (1.2 m) or above have handrails with a vertical height of 29.5 inches (75 cm) to 37 inches (94 cm), measured from the front edge of a step. Removable gates or non-rigid members, such as chains, may be used instead of handrails in special-use applications;

(vi) The maximum work-surface height of mobile ladder stands and platforms does not exceed four times the shortest base dimension, without additional support. For greater heights, outriggers, counterweights, or comparable means that stabilize the mobile ladder stands and platforms and prevent overturning must be used;

(vii) Mobile ladder stands and platforms that have wheels or casters are equipped with a system to impede horizontal movement when an employee is on the stand or platform; and

(viii) No mobile ladder stand or platform moves when an employee is on it.

(2) Design requirements for mobile ladder stands. The employer must ensure:

(i) Steps are uniformly spaced and arranged, with a rise of not more than 10 inches (25 cm) and a depth of not less than 7 inches (18 cm). The slope of the step stringer to which the steps are attached must not be more than 60 degrees, measured from the horizontal;

(ii) Mobile ladder stands with a top step height above 10 feet (3 m) have the top step protected on three sides by a handrail with a vertical height of at least 36 inches (91 cm); and top steps that are 20 inches (51 cm) or more, front to back, have a midrail and toeboard. Removable

gates or non-rigid members, such as chains, may be used instead of handrails in special-use applications; and

(iii) The standing area of mobile ladder stands is within the base frame.

(3) Design requirements for mobile ladder stand platforms. The employer must ensure:

(i) Steps of mobile ladder stand platforms meet the requirements of paragraph (e)(2)(i) of this section. When the employer demonstrates that the requirement is not feasible, steeper slopes or vertical rung ladders may be used, provided the units are stabilized to prevent overturning;

(ii) Mobile ladder stand platforms with a platform height of 4 to 10 feet (1.2 m to 3 m) have, in the platform area, handrails with a vertical height of at least 36 inches (91 cm) and midrails; and

(iii) All ladder stand platforms with a platform height above 10 feet (3 m) have guardrails and toeboards on the exposed sides and ends of the platform.

(iv) Removable gates or non-rigid members, such as chains, may be used on mobile ladder stand platforms instead of handrails and guardrails in special-use applications.

§1910.24 Step bolts and manhole steps.

(a) Step bolts. The employer must ensure:

(1) Each step bolt installed on or after January 17, 2017 in an environment where corrosion may occur is constructed of, or coated with, material that protects against corrosion;

(2) Each step bolt is designed, constructed, and maintained to prevent the employee's foot from slipping off the end of the step bolt;

(3) Step bolts are uniformly spaced at a vertical distance of not less than 12 inches (30 cm) and not more than 18 inches (46 cm) apart, measured center to center (see Figure D-6 of this section). The spacing from the entry and exit surface to the first step bolt may differ from the

spacing between the other step bolts;

(4) Each step bolt has a minimum clear width of 4.5 inches (11 cm);

(5) The minimum perpendicular distance between the centerline of each step bolt to the nearest permanent object in back of the step bolt is 7 inches (18 cm). When the employer demonstrates that an obstruction cannot be avoided, the distance must be at least 4.5 inches (11 cm);

(6) Each step bolt installed before January 17, 2017 is capable of supporting its maximum intended load;

(7) Each step bolt installed on or after January 17, 2017 is capable of supporting at least four times its maximum intended load;

(8) Each step bolt is inspected at the start of the workshift and maintained in accordance with §1910.22; and

(9) Any step bolt that is bent more than 15 degrees from the perpendicular in any direction is removed and replaced with a step bolt that meets the requirements of this section before an employee uses it.

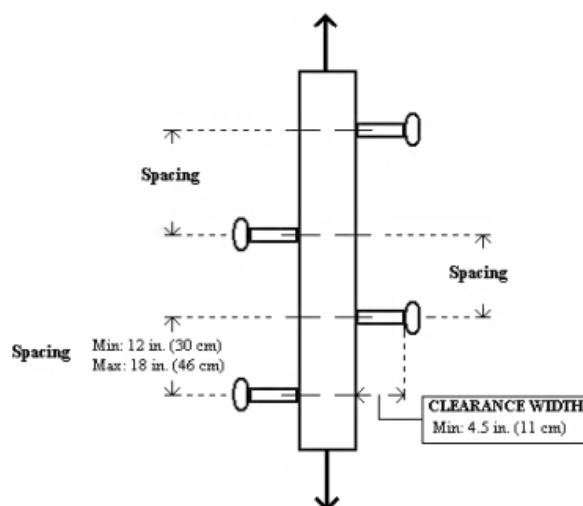

Figure D-6 -- Step Bolt Spacing

(b) Manhole steps. (1) The employer must ensure that each manhole step is capable of supporting its maximum intended load.

(2) The employer must ensure that each manhole step installed on or after January 17, 2017:

(i) Has a corrugated, knurled, dimpled, or other surface that minimizes the possibility of an employee slipping;

(ii) Is constructed of, or coated with, material that protects against corrosion if the manhole step is located in an environment where corrosion may occur;

(iii) Has a minimum clear step width of 10 inches (25 cm);

(iv) Is uniformly spaced at a vertical distance not more than 16 inches (41 cm) apart, measured center to center between steps. The spacing from the entry and exit surface to the first manhole step may differ from the spacing between the other steps.

(v) Has a minimum perpendicular distance between the centerline of the manhole step to the nearest permanent object in back of the step of at least 4.5 inches (11 cm); and

(vi) Is designed, constructed, and maintained to prevent the employee's foot from slipping or sliding off the end.

(3) The employer must ensure that each manhole step is inspected at the start of the work shift and maintained in accordance with §1910.22.

§1910.25 Stairways.

(a) Application. This section covers all stairways (including standard, spiral, ship, and alternating tread-type stairs), except for stairs serving floating roof tanks, stairs on scaffolds, stairs designed into machines or equipment, and stairs on self-propelled motorized equipment.

(b) General requirements. The employer must ensure:

(1) Handrails, stair rail systems, and guardrail systems are provided in accordance with § 1910.28;

(2) Vertical clearance above any stair tread to any overhead obstruction is at least 6 feet, 8 inches (203 cm), as measured from the leading edge of the tread. Spiral stairs must meet the vertical clearance requirements in paragraph (d)(3) of this section.

(3) Stairs have uniform riser heights and tread depths between landings;

(4) Stairway landings and platforms are at least the width of the stair and at least 30 inches (76 cm) in depth, as measured in the direction of travel;

(5) When a door or a gate opens directly on a stairway, a platform is provided, and the swing of the door or gate does not reduce the platform's effective usable depth to:

(i) Less than 20 inches (51 cm) for platforms installed before January 17, 2017; and

(ii) Less than 22 inches (56 cm) for platforms installed on or after January 17, 2017 (see Figure D-7 of this section);

(6) Each stair can support at least five times the normal anticipated live load, but never less than a concentrated load of 1,000 pounds (454 kg) applied at any point;

(7) Standard stairs are used to provide access from one walking-working surface to another when operations necessitate regular and routine travel between levels, including access to operating platforms for equipment. Winding stairways may be used on tanks and similar round structures when the diameter of the tank or structure is at least 5 feet (1.5 m).

(8) Spiral, ship, or alternating tread-type stairs are used only when the employer can demonstrate that it is not feasible to provide standard stairs.

(9) When paragraph (b)(8) of this section allows the use of spiral, ship, or alternating

tread-type stairs, they are installed, used, and maintained in accordance with manufacturer's instructions.

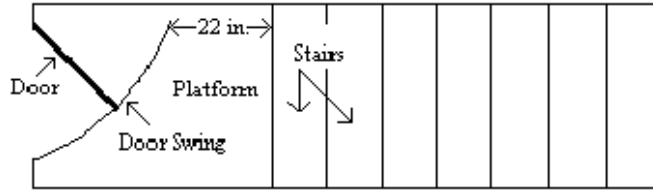

Figure D-7 -- Door or Gate Opening on Stairway

(c) Standard stairs. In addition to paragraph (b) of this section, the employer must ensure standard stairs:

- (1) Are installed at angles between 30 to 50 degrees from the horizontal;
- (2) Have a maximum riser height of 9.5 inches (24 cm);
- (3) Have a minimum tread depth of 9.5 inches (24 cm); and
- (4) Have a minimum width of 22 inches (56 cm) between vertical barriers (see Figure D-8 of this section).

(5) Exception to paragraphs (c)(2) and (3) of this section. The requirements of paragraphs (c)(2) and (c)(3) do not apply to standard stairs installed prior to January 17, 2017. OSHA will deem those stairs in compliance if they meet the dimension requirements specified in Table D-1 of this section or they use a combination that achieves the angle requirements of paragraph (c)(1) of this section.

Table D-1-- Stairway Rise and Tread Dimensions

Angle to horizontal	Rise (in inches)	Tread run (in inches)
30 deg. 35'.....	6 1/2	11

32 deg. 08'	6 3/4	10 3/4
33 deg. 41'	7	10 1/2
35 deg. 16'	7 1/4	10 1/4
36 deg. 52'	7 1/2	10
38 deg. 29'	7 3/4	9 3/4
40 deg. 08'	8	9 1/2
41 deg. 44'	8 1/4	9 1/4
43 deg. 22'	8 1/2	9
45 deg. 00'	8 3/4	8 3/4
46 deg. 38'	9	8 1/2
48 deg. 16'	9 1/4	8 1/4
49 deg. 54'	9 1/2	8

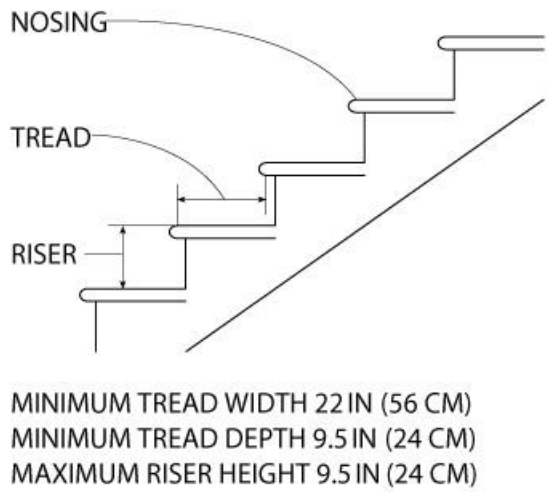

Figure D-8 – Dimensions of Standard Stairs

(d) Spiral stairs. In addition to paragraph (b) of this section, the employer must ensure

spiral stairs:

- (1) Have a minimum clear width of 26 inches (66 cm);
- (2) Have a maximum riser height of 9.5 inches (24 cm);
- (3) Have a minimum headroom above spiral stair treads of at least 6 feet, 6 inches (2 m),

measured from the leading edge of the tread;

(4) Have a minimum tread depth of 7.5 inches (19 cm), measured at a point 12 inches (30 cm) from the narrower edge;

(5) Have a uniform tread size;

(e) Ship stairs. In addition to paragraph (b) of this section, the employer must ensure ship stairs (see Figure D-9 of this section):

- (1) Are installed at a slope of 50 to 70 degrees from the horizontal;
- (2) Have open risers with a vertical rise between tread surfaces of 6.5 to 12 inches (17 to 30 cm);
- (3) Have minimum tread depth of 4 inches (10 cm); and
- (4) Have a minimum tread width of 18 inches (46 cm).



Figure D-9 – Ship Stairs

(f) Alternating tread-type stairs. In addition to paragraph (b) of this section, the employer must ensure alternating tread-type stairs:

- (1) Have a series of treads installed at a slope of 50 to 70 degrees from the horizontal;
- (2) Have a distance between handrails of 17 to 24 inches (51 to 61 cm);
- (3) Have a minimum tread depth of 8.5 inches (22 cm); and
- (4) Have open risers if the tread depth is less than 9.5 inches (24 cm);
- (5) Have a minimum tread width of 7 inches (18 cm), measured at the leading edge of the tread (i.e., nosing).

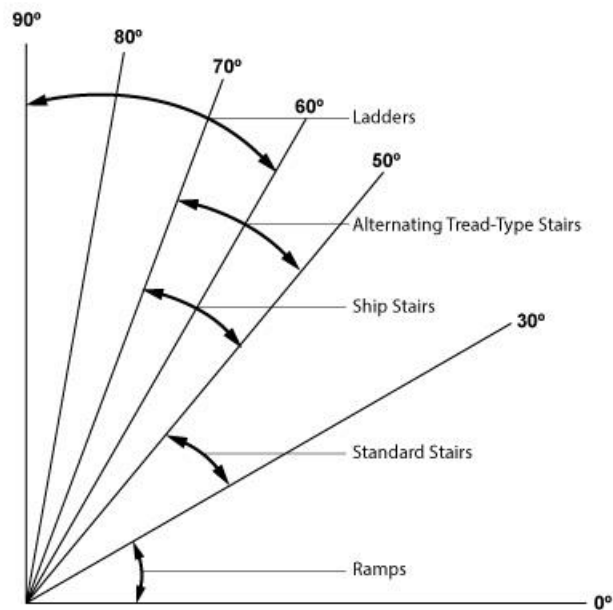

Angle	Type
≤ 30°	Ramps
30° – 50°	Standard Stairs
50° – 70°	Ship Stairs
50° – 70°	Alternating Tread-Type Stairs
60° – 90°	Ladders

Figure D-10 – Angles for Stairs, Ramps, and Ladders

§1910.26 Dockboards.

The employer must ensure that each dockboard used meets the requirements of this section. The employer must ensure:

(a) Dockboards are capable of supporting the maximum intended load in accordance with §1910.22(b);

(b)(1) Dockboards put into initial service on or after January 17, 2017 are designed, constructed, and maintained to prevent transfer vehicles from running off the dockboard edge;

(2) Exception to paragraph (b)(1) of this section. When the employer demonstrates there is no hazard of transfer vehicles running off the dockboard edge, the employer may use dockboards that do not have run-off protection.

(c) Portable dockboards are secured by anchoring them in place or using equipment or devices that prevent the dockboard from moving out of a safe position. When the employer demonstrates that securing the dockboard is not feasible, the employer must ensure there is sufficient contact between the dockboard and the surface to prevent the dockboard from moving out of a safe position;

(d) Measures, such as wheel chocks or sand shoes, are used to prevent the transport vehicle (e.g. a truck, semi-trailer, trailer, or rail car) on which a dockboard is placed, from moving while employees are on the dockboard; and

(e) Portable dockboards are equipped with handholds or other means to permit safe handling of dockboards.

§1910.27 Scaffolds and rope descent systems.

(a) Scaffolds. Scaffolds used in general industry must meet the requirements in 29 CFR part 1926, subpart L (Scaffolds).

(b) Rope descent systems--(1) Anchorages. (i) Before any rope descent system is used, the building owner must inform the employer, in writing that the building owner has identified, tested, certified, and maintained each anchorage so it is capable of supporting at least 5,000 pounds (268 kg), in any direction, for each employee attached. The information must be based on an annual inspection by a qualified person and certification of each anchorage by a qualified person, as necessary, and at least every 10 years.

(ii) The employer must ensure that no employee uses any anchorage before the employer

has obtained written information from the building owner that each anchorage meets the requirements of paragraph (b)(1)(i) of this section. The employer must keep the information for the duration of the job.

(iii) The requirements in paragraphs (b)(1)(i) and (ii) of this section must be implemented no later than November 20, 2017.

(2) Use of rope descent systems. The employer must ensure:

(i) No rope descent system is used for heights greater than 300 feet (91 m) above grade unless the employer demonstrates that it is not feasible to access such heights by any other means or that those means pose a greater hazard than using a rope descent system;

(ii) The rope descent system is used in accordance with instructions, warnings, and design limitations set by the manufacturer or under the direction of a qualified person;

(iii) Each employee who uses the rope descent system is trained in accordance with §1910.30;

(iv) The rope descent system is inspected at the start of each workshift that it is to be used. The employer must ensure damaged or defective equipment is removed from service immediately and replaced;

(v) The rope descent system has proper rigging, including anchorages and tiebacks, with particular emphasis on providing tiebacks when counterweights, cornice hooks, or similar non-permanent anchorages are used;

(vi) Each employee uses a separate, independent personal fall arrest system that meets the requirements of subpart I of this part;

(vii) All components of each rope descent system, except seat boards, are capable of sustaining a minimum rated load of 5,000 pounds (22.2 kN). Seat boards must be capable of

supporting a live load of 300 pounds (136 kg);

(viii) Prompt rescue of each employee is provided in the event of a fall;

(ix) The ropes of each rope descent system are effectively padded or otherwise protected, where they can contact edges of the building, anchorage, obstructions, or other surfaces, to prevent them from being cut or weakened;

(x) Stabilization is provided at the specific work location when descents are greater than 130 feet (39.6 m);

(xi) No employee uses a rope descent system when hazardous weather conditions, such as storms or gusty or excessive wind, are present;

(xii) Equipment, such as tools, squeegees, or buckets, is secured by a tool lanyard or similar method to prevent it from falling; and

(xiii) The ropes of each rope descent system are protected from exposure to open flames, hot work, corrosive chemicals, and other destructive conditions.

§1910.28 Duty to have fall protection and falling object protection.

(a) General. (1) This section requires employers to provide protection for each employee exposed to fall and falling object hazards. Unless stated otherwise, the employer must ensure that all fall protection and falling object protection required by this section meet the criteria in §1910.29, except that personal fall protection systems required by this section meet the criteria of §1910.140.

(2) This section does not apply:

(i) To portable ladders;

(ii) When employers are inspecting, investigating, or assessing workplace conditions or work to be performed prior to the start of work or after all work has been completed. This

exemption does not apply when fall protection systems or equipment meeting the requirements of §1910.29 have been installed and are available for workers to use for pre-work and post-work inspections, investigations, or assessments;

(iii) To fall hazards presented by the exposed perimeters of entertainment stages and the exposed perimeters of rail-station platforms;

(iv) To powered platforms covered by §1910.66(j);

(v) To aerial lifts covered by §1910.67(c)(2)(v);

(vi) To telecommunications work covered by §1910.268(n)(7) and (8); and

(vii) To electric power generation, transmission, and distribution work covered by §1910.269(g)(2)(i).

(b) Protection from fall hazards--(1) Unprotected sides and edges. (i) Except as provided elsewhere in this section, the employer must ensure that each employee on a walking-working surface with an unprotected side or edge that is 4 feet (1.2 m) or more above a lower level is protected from falling by one or more of the following:

(A) Guardrail systems;

(B) Safety net systems; or

(C) Personal fall protection systems, such as personal fall arrest, travel restraint, or positioning systems.

(ii) When the employer can demonstrate that it is not feasible or creates a greater hazard to use guardrail, safety net, or personal fall protection systems on residential roofs, the employer must develop and implement a fall protection plan that meets the requirements of 29 CFR 1926.502(k) and training that meets the requirements of 29 CFR 1926.503(a) and (c).

Note to paragraph (b)(1)(ii) of this section: There is a presumption that it is feasible and will not create a greater hazard to use at least one of the above-listed

fall protection systems specified in paragraph (b)(1)(i) of this section. Accordingly, the employer has the burden of establishing that it is not feasible or creates a greater hazard to provide the fall protection systems specified in paragraph (b)(1)(i) and that it is necessary to implement a fall protection plan that complies with §1926.502(k) in the particular work operation, in lieu of implementing any of those systems.

(iii) When the employer can demonstrate that the use of fall protection systems is not feasible on the working side of a platform used at a loading rack, loading dock, or teeming platform, the work may be done without a fall protection system, provided:

- (A) The work operation for which fall protection is infeasible is in process;
- (B) Access to the platform is limited to authorized employees; and,
- (C) The authorized employees are trained in accordance with §1910.30.

(2) Hoist areas. The employer must ensure:

(i) Each employee in a hoist area is protected from falling 4 feet (1.2 m) or more to a lower level by:

- (A) A guardrail system;
- (B) A personal fall arrest system; or
- (C) A travel restraint system.

(ii) When any portion of a guardrail system, gate, or chains is removed, and an employee must lean through or over the edge of the access opening to facilitate hoisting, the employee is protected from falling by a personal fall arrest system.

(iii) If grab handles are installed at hoist areas, they meet the requirements of §1910.29(l).

(3) Holes. The employer must ensure:

(i) Each employee is protected from falling through any hole (including skylights) that is 4 feet (1.2 m) or more above a lower level by one or more of the following:

- (A) Covers;

- (B) Guardrail systems;
- (C) Travel restraint systems; or
- (D) Personal fall arrest systems.

(ii) Each employee is protected from tripping into or stepping into or through any hole that is less than 4 feet (1.2 m) above a lower level by covers or guardrail systems.

(iii) Each employee is protected from falling into a stairway floor hole by a fixed guardrail system on all exposed sides, except at the stairway entrance. However, for any stairway used less than once per day where traffic across the stairway floor hole prevents the use of a fixed guardrail system (e.g., holes located in aisle spaces), the employer may protect employees from falling into the hole by using a hinged floor hole cover that meets the criteria in §1910.29 and a removable guardrail system on all exposed sides, except at the entrance to the stairway.

(iv) Each employee is protected from falling into a ladderway floor hole or ladderway platform hole by a guardrail system and toeboards erected on all exposed sides, except at the entrance to the hole, where a self-closing gate or an offset must be used.

(v) Each employee is protected from falling through a hatchway and chute-floor hole by:

(A) A hinged floor-hole cover that meets the criteria in §1910.29 and a fixed guardrail system that leaves only one exposed side. When the hole is not in use, the employer must ensure the cover is closed or a removable guardrail system is provided on the exposed sides;

(B) A removable guardrail system and toeboards on not more than two sides of the hole and a fixed guardrail system on all other exposed sides. The employer must ensure the removable guardrail system is kept in place when the hole is not in use; or

(C) A guardrail system or a travel restraint system when a work operation necessitates

passing material through a hatchway or chute floor hole.

(4) Dockboards. (i) The employer must ensure that each employee on a dockboard is protected from falling 4 feet (1.2 m) or more to a lower level by a guardrail system or handrails.

(ii) A guardrail system or handrails are not required when:

(A) Dockboards are being used solely for materials-handling operations using motorized equipment;

(B) Employees engaged in these operations are not exposed to fall hazards greater than 10 feet (3 m); and

(C) Those employees have been trained in accordance with §1910.30.

(5) Runways and similar walkways. (i) The employer must ensure each employee on a runway or similar walkway is protected from falling 4 feet (1.2 m) or more to a lower level by a guardrail system.

(ii) When the employer can demonstrate that it is not feasible to have guardrails on both sides of a runway used exclusively for a special purpose, the employer may omit the guardrail on one side of the runway, provided the employer ensures:

(A) The runway is at least 18 inches (46 cm) wide; and

(B) Each employee is provided with and uses a personal fall arrest system or travel restraint system.

(6) Dangerous equipment. The employer must ensure:

(i) Each employee less than 4 feet (1.2 m) above dangerous equipment is protected from falling into or onto the dangerous equipment by a guardrail system or a travel restraint system, unless the equipment is covered or guarded to eliminate the hazard.

(ii) Each employee 4 feet (1.2 m) or more above dangerous equipment must be protected

from falling by:

- (A) Guardrail systems;
- (B) Safety net systems;
- (C) Travel restraint systems; or
- (D) Personal fall arrest systems.

(7) Openings. The employer must ensure that each employee on a walking-working surface near an opening, including one with a chute attached, where the inside bottom edge of the opening is less than 39 inches (99 cm) above that walking-working surface and the outside bottom edge of the opening is 4 feet (1.2 m) or more above a lower level is protected from falling by the use of:

- (i) Guardrail systems;
- (ii) Safety net systems;
- (iii) Travel restraint systems; or,
- (iv) Personal fall arrest systems.

(8) Repair pits, service pits, and assembly pits less than 10 feet in depth. The use of a fall protection system is not required for a repair pit, service pit, or assembly pit that is less than 10 feet (3 m) deep, provided the employer:

- (i) Limits access within 6 feet (1.8 m) of the edge of the pit to authorized employees trained in accordance with §1910.30;
- (ii) Applies floor markings at least 6 feet (1.8 m) from the edge of the pit in colors that contrast with the surrounding area; or places a warning line at least 6 feet (1.8 m) from the edge of the pit as well as stanchions that are capable of resisting, without tipping over, a force of at least 16 pounds (71 N) applied horizontally against the stanchion at a height of 30 inches (76

cm); or places a combination of floor markings and warning lines at least 6 feet (1.8 m) from the edge of the pit. When two or more pits in a common area are not more than 15 feet (4.5m) apart, the employer may comply by placing contrasting floor markings at least 6 feet (1.8 m) from the pit edge around the entire area of the pits; and

(iii) Posts readily visible caution signs that meet the requirements of §1910.145 and state "Caution—Open Pit."

(9) Fixed ladders (that extend more than 24 feet (7.3 m) above a lower level). (i) For fixed ladders that extend more than 24 feet (7.3 m) above a lower level, the employer must ensure:

(A) Existing fixed ladders. Each fixed ladder installed before November 19, 2018 is equipped with a personal fall arrest system, ladder safety system, cage, or well;

(B) New fixed ladders. Each fixed ladder installed on and after November 19, 2018, is equipped with a personal fall arrest system or a ladder safety system;

(C) Replacement. When a fixed ladder, cage, or well, or any portion of a section thereof, is replaced, a personal fall arrest system or ladder safety system is installed in at least that section of the fixed ladder, cage, or well where the replacement is located; and

(D) Final deadline. On and after November 18, 2036, all fixed ladders are equipped with a personal fall arrest system or a ladder safety system.

(ii) When a one-section fixed ladder is equipped with a personal fall protection or a ladder safety system or a fixed ladder is equipped with a personal fall arrest or ladder safety system on more than one section, the employer must ensure:

(A) The personal fall arrest system or ladder safety system provides protection throughout the entire vertical distance of the ladder, including all ladder sections; and

(B) The ladder has rest platforms provided at maximum intervals of 150 feet (45.7 m).

(iii) The employer must ensure ladder sections having a cage or well:

(A) Are offset from adjacent sections; and

(B) Have landing platforms provided at maximum intervals of 50 feet (15.2 m).

(iv) The employer may use a cage or well in combination with a personal fall arrest system or ladder safety system provided that the cage or well does not interfere with the operation of the system.

(10) Outdoor advertising (billboards). (i) The requirements in paragraph (b)(9) of this section, and other requirements in subparts D and I of this part, apply to fixed ladders used in outdoor advertising activities.

(ii) When an employee engaged in outdoor advertising climbs a fixed ladder before November 19, 2018 that is not equipped with a cage, well, personal fall arrest system, or a ladder safety system the employer must ensure the employee:

(A) Receives training and demonstrates the physical capability to perform the necessary climbs in accordance with §1910.29(h);

(B) Wears a body harness equipped with an 18-inch (46 cm) rest lanyard;

(C) Keeps both hands free of tools or material when climbing on the ladder; and

(D) Is protected by a fall protection system upon reaching the work position.

(11) Stairways. The employer must ensure:

(i) Each employee exposed to an unprotected side or edge of a stairway landing that is 4 feet (1.2 m) or more above a lower level is protected by a guardrail or stair rail system;

(ii) Each flight of stairs having at least 3 treads and at least 4 risers is equipped with stair rail systems and handrails as follows:

Table D-2 -- Stairway Handrail Requirements

Stair width	Enclosed	One open side	Two open sides	With earth built up on both sides
<i>Less than 44 inches (1.1 m).</i>	<i>At least one handrail</i>	<i>One stair rail system with handrail on open side.</i>	<i>One stair rail system with handrail on each open side.</i>	
<i>44 inches (1.1 m) to 88 inches (2.2 m).</i>	<i>One handrail on each enclosed side</i>	<i>One stair rail system with handrail on open side and one handrail on enclosed side.</i>	<i>One stair rail system with handrail on each open side.</i>	
<i>Greater than 88 inches (2.2 m).</i>	<i>One handrail on each enclosed side and one intermediate handrail located in the middle of the stair</i>	<i>One stair rail system with handrail on open side, one handrail on enclosed side, and one intermediate handrail located in the middle of the stair.</i>	<i>One stair rail system with handrail on each open side and one intermediate handrail located in the middle of the stair.</i>	
<i>Exterior stairs less than 44 inches (1.1 m).</i>				<i>One handrail on at least one side.</i>

Note to table: The width of the stair must be clear of all obstructions except handrails.

(iii) Each ship stairs and alternating tread type stairs is equipped with handrails on both sides.

(12) Scaffolds and rope descent systems. The employer must ensure:

(i) Each employee on a scaffold is protected from falling in accordance 29 CFR part 1926, subpart L; and

(ii) Each employee using a rope descent system 4 feet (1.2 m) or more above a lower level is protected from falling by a personal fall arrest system.

(13) Work on low-slope roofs. (i) When work is performed less than 6 feet (1.6 m) from the roof edge, the employer must ensure each employee is protected from falling by a guardrail system, safety net system, travel restraint system, or personal fall arrest system.

(ii) When work is performed at least 6 feet (1.6 m) but less than 15 feet (4.6 m) from the roof edge, the employer must ensure each employee is protected from falling by using a guardrail system, safety net system, travel restraint system, or personal fall arrest system. The employer may use a designated area when performing work that is both infrequent and temporary.

(iii) When work is performed 15 feet (4.6 m) or more from the roof edge, the employer must:

(A) Protect each employee from falling by a guardrail system, safety net system, travel restraint system, or personal fall arrest system or a designated area. The employer is not required to provide any fall protection, provided the work is both infrequent and temporary; and

(B) Implement and enforce a work rule prohibiting employees from going within 15 feet (4.6 m) of the roof edge without using fall protection in accordance with paragraphs (b)(13)(i) and (ii) of this section.

(14) Slaughtering facility platforms. (i) The employer must protect each employee on the unprotected working side of a slaughtering facility platform that is 4 feet (1.2 m) or more above a lower level from falling by using:

(A) Guardrail systems; or

(B) Travel restraint systems.

(ii) When the employer can demonstrate the use of a guardrail or travel restraint system is not feasible, the work may be done without those systems provided:

(A) The work operation for which fall protection is infeasible is in process;

(B) Access to the platform is limited to authorized employees; and

(C) The authorized employees are trained in accordance with §1910.30.

(15) Walking-working surfaces not otherwise addressed. Except as provided elsewhere

in this section or by other subparts of this part, the employer must ensure each employee on a walking-working surface 4 feet (1.2 m) or more above a lower level is protected from falling by:

- (i) Guardrail systems;
- (ii) Safety net systems; or
- (iii) Personal fall protection systems, such as personal fall arrest, travel restraint, or positioning systems.

(c) Protection from falling objects. When an employee is exposed to falling objects, the employer must ensure that each employee wears head protection that meets the requirements of subpart I of this part. In addition, the employer must protect employees from falling objects by implementing one or more of the following:

- (1) Erecting toeboards, screens, or guardrail systems to prevent objects from falling to a lower level;
- (2) Erecting canopy structures and keeping potential falling objects far enough from an edge, hole, or opening to prevent them from falling to a lower level; or
- (3) Barricading the area into which objects could fall, prohibiting employees from entering the barricaded area, and keeping objects far enough from an edge or opening to prevent them from falling to a lower level.

§1910.29 Fall protection systems and falling object protection—criteria and practices.

(a) General requirements. The employer must:

- (1) Ensure each fall protection system and falling object protection, other than personal fall protection systems, that this part requires meets the requirements in this section. The employer must ensure each personal fall protection system meets the requirements in subpart I of this part; and

(2) Provide and install all fall protection systems and falling object protection this subpart requires, and comply with the other requirements in this subpart before any employee begins work that necessitates fall or falling object protection.

(b) Guardrail systems. The employer must ensure guardrail systems meet the following requirements:

(1) The top edge height of top rails, or equivalent guardrail system members, are 42 inches (107 cm), plus or minus 3 inches (8 cm), above the walking-working surface. The top edge height may exceed 45 inches (114 cm), provided the guardrail system meets all other criteria of paragraph (b) of this section (see Figure D-11 of this section).

(2) Midrails, screens, mesh, intermediate vertical members, solid panels, or equivalent intermediate members are installed between the walking-working surface and the top edge of the guardrail system as follows when there is not a wall or parapet that is at least 21 inches (53 cm) high:

(i) Midrails are installed at a height midway between the top edge of the guardrail system and the walking-working surface;

(ii) Screens and mesh extend from the walking-working surface to the top rail and along the entire opening between top rail supports;

(iii) Intermediate vertical members (such as balusters) are installed no more than 19 inches (48 cm) apart; and

(iv) Other equivalent intermediate members (such as additional midrails and architectural panels) are installed so that the openings are not more than 19 inches (48 cm) wide.

(3) Guardrail systems are capable of withstanding, without failure, a force of at least 200 pounds (890 N) applied in a downward or outward direction within 2 inches (5 cm) of the top

edge, at any point along the top rail.

(4) When the 200-pound (890-N) test load is applied in a downward direction, the top rail of the guardrail system must not deflect to a height of less than 39 inches (99 cm) above the walking-working surface.

(5) Midrails, screens, mesh, intermediate vertical members, solid panels, and other equivalent intermediate members are capable of withstanding, without failure, a force of at least 150 pounds (667 N) applied in any downward or outward direction at any point along the intermediate member.

(6) Guardrail systems are smooth-surfaced to protect employees from injury, such as punctures or lacerations, and to prevent catching or snagging of clothing.

(7) The ends of top rails and midrails do not overhang the terminal posts, except where the overhang does not pose a projection hazard for employees.

(8) Steel banding and plastic banding are not used for top rails or midrails.

(9) Top rails and midrails are at least 0.25-inches (0.6 cm) in diameter or in thickness.

(10) When guardrail systems are used at hoist areas, a removable guardrail section, consisting of a top rail and midrail, are placed across the access opening between guardrail sections when employees are not performing hoisting operations. The employer may use chains or gates instead of a removable guardrail section at hoist areas if the employer demonstrates the chains or gates provide a level of safety equivalent to guardrails.

(11) When guardrail systems are used around holes, they are installed on all unprotected sides or edges of the hole.

(12) For guardrail systems used around holes through which materials may be passed:

(i) When materials are being passed through the hole, not more than two sides of the

guardrail system are removed; and

(ii) When materials are not being passed through the hole, the hole must be guarded by a guardrail system along all unprotected sides or edges or closed over with a cover.

(13) When guardrail systems are used around holes that serve as points of access (such as ladderways), the guardrail system opening:

(i) Has a self-closing gate that slides or swings away from the hole, and is equipped with a top rail and midrail or equivalent intermediate member that meets the requirements in paragraph (b) of this section; or

(ii) Is offset to prevent an employee from walking or falling into the hole;

(14) Guardrail systems on ramps and runways are installed along each unprotected side or edge.

(15) Manila or synthetic rope used for top rails or midrails are inspected as necessary to ensure that the rope continues to meet the strength requirements in paragraphs (b)(3) and (5) of this section.

Note to paragraph (b) of this section: The criteria and practices requirements for guardrail systems on scaffolds are contained in 29 CFR part 1926, subpart L.

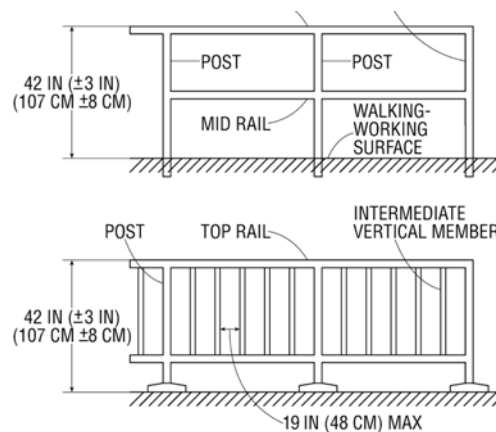

Figure D-11 – Guard Rail Systems

(c) Safety net systems. The employer must ensure each safety net system meets the

requirements in 29 CFR part 1926, subpart M.

(d) Designated areas. (1) When the employer uses a designated area, the employer must ensure:

(i) Employees remain within the designated area while work operations are underway;
and

(ii) The perimeter of the designated area is delineated with a warning line consisting of a rope, wire, tape, or chain that meets the requirements of paragraphs (d)(2) and (3) of this section.

(2) The employer must ensure each warning line:

(i) Has a minimum breaking strength of 200 pounds (0.89 kN);

(ii) Is installed so its lowest point, including sag, is not less than 34 inches (86 cm) and not more than 39 inches (99 cm) above the walking-working surface;

(iii) Is supported in such a manner that pulling on one section of the line will not result in slack being taken up in adjacent sections causing the line to fall below the limits specified in paragraph (d)(2)(ii) of this section;

(iv) Is clearly visible from a distance of 25 feet (7.6 m) away, and anywhere within the designated area;

(v) Is erected as close to the work area as the task permits; and

(vi) Is erected not less than 6 feet (1.8 m) from the roof edge for work that is both temporary and infrequent, or not less than 15 feet (4.6 m) for other work.

(3) When mobile mechanical equipment is used to perform work that is both temporary and infrequent in a designated area, the employer must ensure the warning line is erected not less than 6 feet (1.8 m) from the unprotected side or edge that is parallel to the direction in which the mechanical equipment is operated, and not less than 10 feet (3 m) from the unprotected side or

edge that is perpendicular to the direction in which the mechanical equipment is operated.

(e) Covers. The employer must ensure each cover for a hole in a walking-working surface:

(1) Is capable of supporting without failure, at least twice the maximum intended load that may be imposed on the cover at any one time; and

(2) Is secured to prevent accidental displacement.

(f) Handrails and stair rail systems. The employer must ensure:

(1) Height criteria. (i) Handrails are not less than 30 inches (76 cm) and not more than 38 inches (97 cm), as measured from the leading edge of the stair tread to the top surface of the handrail (see Figure D-12 of this section).

(ii) The height of stair rail systems meets the following:

(A) The height of stair rail systems installed before January 17, 2017 is not less than 30 inches (76 cm) from the leading edge of the stair tread to the top surface of the top rail; and

(B) The height of stair rail systems installed on or after January 17, 2017 is not less than 42 inches (107 cm) from the leading edge of the stair tread to the top surface of the top rail.

(iii) The top rail of a stair rail system may serve as a handrail only when:

(A) The height of the stair rail system is not less than 36 inches (91 cm) and not more than 38 inches (97 cm) as measured at the leading edge of the stair tread to the top surface of the top rail (see Figure D-13 of this section); and

(B) The top rail of the stair rail system meets the other handrail requirements in paragraph (f) of this section.

(2) Finger clearance. The minimum clearance between handrails and any other object is 2.25 inches (5.7 cm).

(3) Surfaces. Handrails and stair rail systems are smooth-surfaced to protect employees from injury, such as punctures or lacerations, and to prevent catching or snagging of clothing.

(4) Openings in stair rails. No opening in a stair rail system exceeds 19 inches (48 cm) at its least dimension.

(5) Handhold. Handrails have the shape and dimension necessary so that employees can grasp the handrail firmly.

(6) Projection hazards. The ends of handrails and stair rail systems do not present any projection hazards.

(7) Strength criteria. Handrails and the top rails of stair rail systems are capable of withstanding, without failure, a force of at least 200 pounds (890 N) applied in any downward or outward direction within 2 inches (5 cm) of any point along the top edge of the rail.

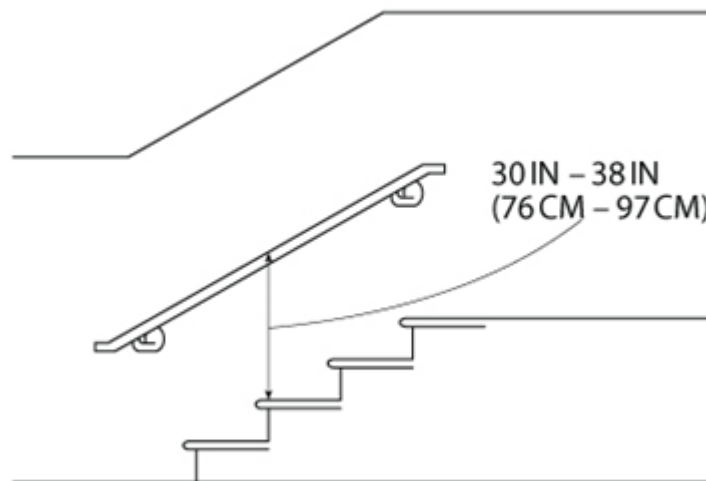

Figure D-12 – Handrail Measurement

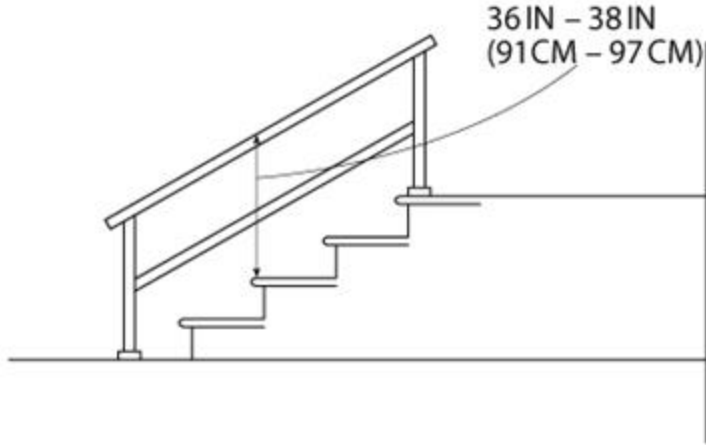

Figure D-13 – Combination Handrail and Stair Rail

(g) Cages, wells, and platforms used with fixed ladders. The employer must ensure:

(1) Cages and wells installed on fixed ladders are designed, constructed, and maintained to permit easy access to, and egress from, the ladder that they enclose (see Figures D-14 and D-15 of this section);

(2) Cages and wells are continuous throughout the length of the fixed ladder, except for access, egress, and other transfer points;

(3) Cages and wells are designed, constructed, and maintained to contain employees in the event of a fall, and to direct them to a lower landing; and

(4) Platforms used with fixed ladders provide a horizontal surface of at least 24 inches by 30 inches (61 cm by 76 cm).

Note to paragraph (g): Section 1910.28 establishes the requirements that employers must follow on the use of cages and wells as a means of fall protection.

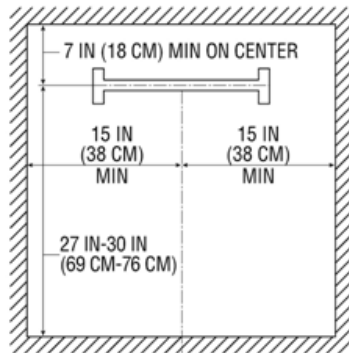

Figure D-14 -- Clearances for Fixed Ladders in Wells

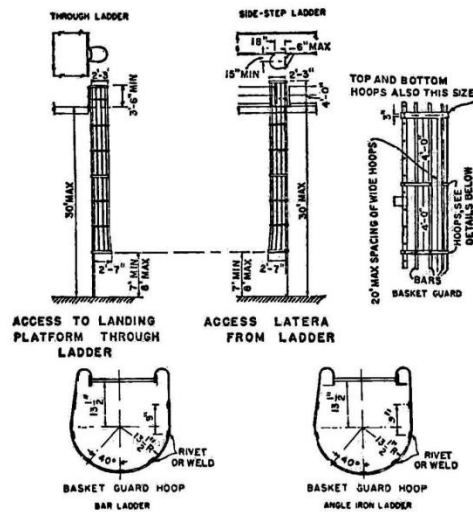

Figure D-15 -- Example of General Construction of Cages

(h) Outdoor advertising. This paragraph (h) applies only to employers engaged in outdoor advertising operations (see §1910.28(b)(10)). Employers must ensure that each employee who climbs a fixed ladder without fall protection:

(1) Is physically capable, as demonstrated through observations of actual climbing activities or by a physical examination, to perform the duties that may be assigned, including climbing fixed ladders without fall protection;

(2) Has successfully completed a training or apprenticeship program that includes hands-

on training on the safe climbing of ladders and is retrained as necessary to maintain the necessary skills;

(3) Has the skill to climb ladders safely, as demonstrated through formal classroom training or on-the-job training, and performance observation; and

(4) Performs climbing duties as a part of routine work activity.

(i) Ladder safety systems. The employer must ensure:

(1) Each ladder safety system allows the employee to climb up and down using both hands and does not require that the employee continuously hold, push, or pull any part of the system while climbing;

(2) The connection between the carrier or lifeline and the point of attachment to the body harness or belt does not exceed 9 inches (23 cm);

(3) Mountings for rigid carriers are attached at each end of the carrier, with intermediate mountings spaced, as necessary, along the entire length of the carrier so the system has the strength to stop employee falls;

(4) Mountings for flexible carriers are attached at each end of the carrier and cable guides for flexible carriers are installed at least 25 feet (7.6 m) apart but not more than 40 feet (12.2 m) apart along the entire length of the carrier;

(5) The design and installation of mountings and cable guides does not reduce the design strength of the ladder; and

(6) Ladder safety systems and their support systems are capable of withstanding, without failure, a drop test consisting of an 18-inch (41-cm) drop of a 500-pound (227-kg) weight.

(j) Personal fall protection systems. Body belts, harnesses, and other components used in personal fall arrest systems, work positioning systems, and travel restraint systems must meet the

requirements of § 1910.140.

(k) Protection from falling objects. (1) The employers must ensure toeboards used for falling object protection:

(i) Are erected along the exposed edge of the overhead walking-working surface for a length that is sufficient to protect employees below.

(ii) Have a minimum vertical height of 3.5 inches (9 cm) as measured from the top edge of the toeboard to the level of the walking-working surface.

(iii) Do not have more than a 0.25-inch (0.5-cm) clearance or opening above the walking-working surface.

(iv) Are solid or do not have any opening that exceeds 1 inch (3 cm) at its greatest dimension.

(v) Have a minimum height of 2.5 inches (6 cm) when used around vehicle repair, service, or assembly pits. Toeboards may be omitted around vehicle repair, service, or assembly pits when the employer can demonstrate that a toeboard would prevent access to a vehicle that is over the pit.

(vi) Are capable of withstanding, without failure, a force of at least 50 pounds (222 N) applied in any downward or outward direction at any point along the toeboard.

(2) The employer must ensure:

(i) Where tools, equipment, or materials are piled higher than the top of the toeboard, paneling or screening is installed from the toeboard to the midrail of the guardrail system and for a length that is sufficient to protect employees below. If the items are piled higher than the midrail, the employer also must install paneling or screening to the top rail and for a length that is sufficient to protect employees below; and

(ii) All openings in guardrail systems are small enough to prevent objects from falling through the opening.

(3) The employer must ensure canopies used for falling object protection are strong enough to prevent collapse and to prevent penetration by falling objects.

(1) Grab handles. The employer must ensure each grab handle:

(1) Is not less than 12 inches (30 cm) long;

(2) Is mounted to provide at least 3 inches (8 cm) of clearance from the framing or opening; and

(3) Is capable of withstanding a maximum horizontal pull-out force equal to two times the maximum intended load or 200 pounds (890 N), whichever is greater.

§1910.30 Training requirements.

(a) Fall hazards. (1) Before any employee is exposed to a fall hazard, the employer must provide training for each employee who uses personal fall protection systems or who is required to be trained as specified elsewhere in this subpart. Employers must ensure employees are trained in the requirements of this paragraph on or before May 17, 2017.

(2) The employer must ensure that each employee is trained by a qualified person.

(3) The employer must train each employee in at least the following topics:

(i) The nature of the fall hazards in the work area and how to recognize them;

(ii) The procedures to be followed to minimize those hazards;

(iii) The correct procedures for installing, inspecting, operating, maintaining, and disassembling the personal fall protection systems that the employee uses; and

(iv) The correct use of personal fall protection systems and equipment specified in paragraph (a)(1) of this section, including, but not limited to, proper hook-up, anchoring, and tie-

off techniques, and methods of equipment inspection and storage, as specified by the manufacturer.

(b) Equipment hazards. (1) The employer must train each employee on or before May 17, 2017 in the proper care, inspection, storage, and use of equipment covered by this subpart before an employee uses the equipment.

(2) The employer must train each employee who uses a dockboard to properly place and secure it to prevent unintentional movement.

(3) The employer must train each employee who uses a rope descent system in proper rigging and use of the equipment in accordance with §1910.27.

(4) The employer must train each employee who uses a designated area in the proper set-up and use of the area.

(c) Retraining. The employer must retrain an employee when the employer has reason to believe the employee does not have the understanding and skill required by paragraphs (a) and (b) of this section. Situations requiring retraining include, but are not limited to, the following:

(1) When changes in the workplace render previous training obsolete or inadequate;

(2) When changes in the types of fall protection systems or equipment to be used render previous training obsolete or inadequate; or

(3) When inadequacies in an affected employee's knowledge or use of fall protection systems or equipment indicate that the employee no longer has the requisite understanding or skill necessary to use equipment or perform the job safely.

(d) Training must be understandable. The employer must provide information and training to each employee in a manner that the employee understands.

Subpart F – [Amended]

4. Revise the authority citation for subpart F to read as follows:

AUTHORITY: 29 U.S.C. 653, 655, and 657; Secretary of Labor's Order No. 12-71 (36 FR 8754), 8-76 (41 FR 25059), 9-83 (48 FR 35736), 1-90 (55 FR 9033), 5-2007 (72 FR 31159), or 1-2012 (77 FR 3912), as applicable; and 29 CFR part 1911.

5. In §1910.66:

- a. Revise paragraphs (b)(2)(i), (c)(3), (f)(5)(ii)(L) and (M), (f)(5)(iii)(B), and (j);
- b. Remove and reserve appendix C; and
- c. Revise appendix D, paragraph (c)(4).

The revisions read as follows:

§1910.66 Powered platforms for building maintenance.

* * * * *

(b) * * *

(2) * * *

(i) Permanent installations in existence and/or completed before July 23, 1990 shall comply with paragraphs (g), (h), (i), (j) and appendix C to subpart I of this part.

* * *

(c) * * *

(3) Building owners of all installations, new and existing, shall inform the employer in writing that the installation has been inspected, tested, and maintained in compliance with the requirements of paragraphs (g) and (h) of this section and that all anchorages meet the requirements of §1910.140(c)(13).

* * * * *

(f) * * *

(5) * * *

(ii) * * *

(L) The platform shall be provided with a secondary wire rope suspension system if the platform contains overhead structures which restrict the emergency egress of employees. A horizontal lifeline or a direct connection anchorage shall be provided as part of a personal fall arrest system that meets the requirements of subpart I of this part for each employee on such a platform.

(M) A vertical lifeline shall be provided as part of a personal fall arrest system that meets the requirements of subpart I of this part for each employee on a working platform suspended by two or more wire ropes, if the failure of one wire rope or suspension attachment will cause the platform to upset. If a secondary wire rope suspension is used, vertical lifelines are not required for the personal fall arrest system, provided that each employee is attached to a horizontal lifeline anchored to the platform.

* * * * *

(iii) * * *

(B) Each single point suspended working platform shall be provided with a secondary wire rope suspension system which will prevent the working platform from falling should there be a failure of the primary means of support, or if the platform contains overhead structures which restrict the egress of the employees. A horizontal life line or a direct connection anchorage shall be provided as part of a personal fall arrest system that meets the requirements of subpart I of this part for each employee on the platform.

* * * * *

(j) Personal fall protection. Employees on working platforms shall be protected by a

personal fall arrest system meeting the requirements of subpart I of this part and as otherwise provided by this standard.

* * * * *

Appendix C to §1910.66 [Reserved]

Appendix D to §1910.66 – Existing Installations (Mandatory)

* * * * *

(c) * * *

(4) Access to the roof car. Safe access to the roof car and from the roof car to the working platform shall be provided. If the access to the roof car at any point of its travel is not over the roof area or where otherwise necessary for safety, then self-closing, self-locking gates shall be provided. Access to and from roof cars must comply with the requirements of subpart D of this part.

* * * * *

6. In §1910.67, revise paragraph (c)(2)(v) to read as follows:

§1910.67 Vehicle-mounted elevating and rotating work platforms.

* * * * *

(c) * * *

(2) * * *

(v) A personal fall arrest or travel restraint system that meets the requirements in subpart I of this part shall be worn and attached to the boom or basket when working from an aerial lift.

* * * * *

7. In §1910.68, revise paragraphs (b)(8)(ii) and (b)(12) to read as follows:

§1910.68 Manlifts.

* * * * *

(b) * * *

(8) * * *

(ii) Construction. The rails shall be standard guardrails with toeboards that meet the requirements in subpart D of this part.

* * * * *

(12) Emergency exit ladder. A fixed metal ladder accessible from both the “up” and “down” run of the manlift shall be provided for the entire travel of the manlift. Such ladders shall meet the requirements in subpart D of this part.

* * * * *

Subpart I—[Amended]

8. Revise the authority citation for subpart I to read as follows:

AUTHORITY: 29 U.S.C. 653, 655, 657; Secretary of Labor’s Order No. 12-71 (36 FR 8754), 8-76 (41 FR 25059), 9-83 (48 FR 35736), 1-90 (55 FR 9033), 6-96 (62 FR 111), 3-2000 (65 FR 50017), 5-2002 (67 FR 65008), 5-2007 (72 FR 31159), 4-2010 (75 FR 55355), or 1-2012 (77 FR 3912), as applicable; and 29 CFR part 1911.

9. In §1910.132, revise paragraph (g) to read as follows:

§1910.132 General requirements.

* * * * *

(g) Paragraphs (d) and (f) of this section apply only to §§1910.133, 1910.135, 1910.136,

1910.138, and 1910.140. Paragraphs (d) and (f) of this section do not apply to §§1910.134 and 1910.137.

* * * * *

§1910.139 [Added and Reserved]

10. Add reserved § 1910.139.

11. Add §1910.140 to read as follows:

§1910.140 Personal fall protection systems.

(a) Scope and application. This section establishes performance, care, and use criteria for all personal fall protection systems. The employer must ensure that each personal fall protection system used to comply with this part must meet the requirements of this section.

(b) Definitions. The following definitions apply to this section:

Anchorage means a secure point of attachment for equipment such as lifelines, lanyards, or deceleration devices.

Belt terminal means an end attachment of a window cleaner's positioning system used for securing the belt or harness to a window cleaner's belt anchor.

Body belt means a strap with means both for securing about the waist and for attaching to other components such as a lanyard used with positioning systems, travel restraint systems, or ladder safety systems.

Body harness means straps that secure about the employee in a manner to distribute the fall arrest forces over at least the thighs, pelvis, waist, chest, and shoulders, with a means for attaching the harness to other components of a personal fall protection system.

Carabiner means a connector generally comprised of a trapezoidal or oval shaped body with a closed gate or similar arrangement that may be opened to attach another object and, when released, automatically closes to retain the object.

Competent person means a person who is capable of identifying existing and predictable hazards in any personal fall protection system or any component of it, as well as in their application and uses with related equipment, and who has authorization to take prompt, corrective action to eliminate the identified hazards.

Connector means a device used to couple (connect) parts of the fall protection system together.

D-ring means a connector used:

- (i) In a harness as an integral attachment element or fall arrest attachment;
- (ii) In a lanyard, energy absorber, lifeline, or anchorage connector as an integral connector; or
- (iii) In a positioning or travel restraint system as an attachment element.

Deceleration device means any mechanism that serves to dissipate energy during a fall.

Deceleration distance means the vertical distance a falling employee travels from the point at which the deceleration device begins to operate, excluding lifeline elongation and free fall distance, until stopping. It is measured as the distance between the location of an employee's body harness attachment point at the moment of activation (at the onset of fall arrest forces) of the deceleration device during a fall, and the location of that attachment point after the employee comes to a full stop.

Equivalent means alternative designs, equipment, materials, or methods that the employer can demonstrate will provide an equal or greater degree of safety for employees compared to the designs, equipment, materials, or methods specified in the standard.

Free fall means the act of falling before the personal fall arrest system begins to apply force to arrest the fall.

Free fall distance means the vertical displacement of the fall arrest attachment point on the employee's body belt or body harness between onset of the fall and just before the system begins to apply force to arrest the fall. This distance excludes deceleration distance, lifeline and lanyard elongation, but includes any deceleration device slide distance or self-retracting lifeline/lanyard extension before the devices operate and fall arrest forces occur.

Lanyard means a flexible line of rope, wire rope, or strap that generally has a connector at each end for connecting the body belt or body harness to a deceleration device, lifeline, or anchorage.

Lifeline means a component of a personal fall protection system consisting of a flexible line for connection to an anchorage at one end so as to hang vertically (vertical lifeline), or for connection to anchorages at both ends so as to stretch horizontally (horizontal lifeline), and serves as a means for connecting other components of the system to the anchorage.

Personal fall arrest system means a system used to arrest an employee in a fall from a walking-working surface. It consists of a body harness, anchorage, and connector. The means of connection may include a lanyard, deceleration device, lifeline, or a suitable combination of these.

Personal fall protection system means a system (including all components) an employer uses to provide protection from falling or to safely arrest an employee's fall if one occurs.

Examples of personal fall protection systems include personal fall arrest systems, positioning systems, and travel restraint systems.

Positioning system (work-positioning system) means a system of equipment and connectors that, when used with a body harness or body belt, allows an employee to be supported on an elevated vertical surface, such as a wall or window sill, and work with both hands free. Positioning systems also are called “positioning system devices” and “work-positioning equipment.”

Qualified describes a person who, by possession of a recognized degree, certificate, or professional standing, or who by extensive knowledge, training, and experience has successfully demonstrated the ability to solve or resolve problems relating to the subject matter, the work, or the project.

Rope grab means a deceleration device that travels on a lifeline and automatically, by friction, engages the lifeline and locks so as to arrest the fall of an employee. A rope grab usually employs the principle of inertial locking, cam/lever locking, or both.

Safety factor means the ratio of the design load and the ultimate strength of the material.

Self-retracting lifeline/lanyard means a deceleration device containing a drum-wound line that can be slowly extracted from, or retracted onto, the drum under slight tension during normal movement by the employee. At the onset of a fall, the device automatically locks the drum and arrests the fall.

Snaphook means a connector comprised of a hook-shaped body with a normally closed gate, or similar arrangement that may be manually opened to permit the hook to receive an object. When released, the snaphook automatically closes to retain the object. Opening a snaphook requires two separate actions. Snaphooks are generally one of two types:

(i) Automatic-locking type (permitted) with a self-closing and self-locking gate that remains closed and locked until intentionally unlocked and opened for connection or disconnection; and

(ii) Non-locking type (prohibited) with a self-closing gate that remains closed, but not locked, until intentionally opened for connection or disconnection.

Travel restraint (tether) line means a rope or wire rope used to transfer forces from a body support to an anchorage or anchorage connector in a travel restraint system.

Travel restraint system means a combination of an anchorage, anchorage connector, lanyard (or other means of connection), and body support that an employer uses to eliminate the possibility of an employee going over the edge of a walking-working surface.

Window cleaner's belt means a positioning belt that consists of a waist belt, an integral terminal runner or strap, and belt terminals.

Window cleaner's belt anchor (window anchor) means specifically designed fall-preventing attachment points permanently affixed to a window frame or to a building part immediately adjacent to the window frame, for direct attachment of the terminal portion of a window cleaner's belt.

Window cleaner's positioning system means a system which consists of a window cleaner's belt secured to window anchors.

Work-positioning system (see Positioning system in this paragraph (b)).

(c) General requirements. The employer must ensure that personal fall protection systems meet the following requirements. Additional requirements for personal fall arrest systems and positioning systems are contained in paragraphs (d) and (e) of this section, respectively.

(1) Connectors must be drop forged, pressed or formed steel, or made of equivalent materials.

(2) Connectors must have a corrosion-resistant finish, and all surfaces and edges must be smooth to prevent damage to interfacing parts of the system.

(3) When vertical lifelines are used, each employee must be attached to a separate lifeline.

(4) Lanyards and vertical lifelines must have a minimum breaking strength of 5,000 pounds (22.2 kN).

(5) Self-retracting lifelines and lanyards that automatically limit free fall distance to 2 feet (0.61 m) or less must have components capable of sustaining a minimum tensile load of 3,000 pounds (13.3 kN) applied to the device with the lifeline or lanyard in the fully extended position.

(6) A competent person or qualified person must inspect each knot in a lanyard or vertical lifeline to ensure that it meets the requirements of paragraphs (c)(4) and (5) of this section before any employee uses the lanyard or lifeline.

(7) D-rings, snaphooks, and carabiners must be capable of sustaining a minimum tensile load of 5,000 pounds (22.2 kN).

(8) D-rings, snaphooks, and carabiners must be proof tested to a minimum tensile load of 3,600 pounds (16 kN) without cracking, breaking, or incurring permanent deformation. The gate strength of snaphooks and carabiners, must be proof tested to 3,600 lbs. (16 kN) in all directions.

(9) Snaphooks and carabiners must be the automatic locking type that require at least two separate, consecutive movements to open.

(10) Snaphooks and carabiners must not be connected to any of the following unless they are designed for such connections:

- (i) Directly to webbing, rope, or wire rope;
- (ii) To each other;
- (iii) To a D-ring to which another snaphook, carabiner, or connector is attached;
- (iv) To a horizontal life line; or
- (v) To any object that is incompatibly shaped or dimensioned in relation to the snaphook

or carabiner such that unintentional disengagement could occur when the connected object depresses the snaphook or carabiner gate, allowing the components to separate.

(11) The employer must ensure that each horizontal lifeline:

- (i) Is designed, installed, and used under the supervision of a qualified person; and
- (ii) Is part of a complete personal fall arrest system that maintains a safety factor of at

least two.

(12) Anchorages used to attach to personal fall protection equipment must be independent of any anchorage used to suspend employees or platforms on which employees work.

Anchorages used to attach to personal fall protection equipment on mobile work platforms on powered industrial trucks must be attached to an overhead member of the platform, at a point located above and near the center of the platform.

(13) Anchorages, except window cleaners' belt anchors covered by paragraph (e) of this section, must be:

- (i) Capable of supporting at least 5,000 pounds (22.2 kN) for each employee attached; or
- (ii) Designed, installed, and used, under the supervision of qualified person, as part of a

complete personal fall protection system that maintains a safety factor of at least two.

(14) Travel restraint lines must be capable of sustaining a tensile load of at least 5,000 pounds (22.2 kN).

(15) Lifelines must not be made of natural fiber rope. Polypropylene rope must contain an ultraviolet (UV) light inhibitor.

(16) Personal fall protection systems and their components must be used exclusively for employee fall protection and not for any other purpose, such as hoisting equipment or materials.

(17) A personal fall protection system or its components subjected to impact loading must be removed from service immediately and not used again until a competent person inspects the system or components and determines that it is not damaged and safe for use for employee personal fall protection.

(18) Personal fall protection systems must be inspected before initial use during each workshift for mildew, wear, damage, and other deterioration, and defective components must be removed from service.

(19) Ropes, belts, lanyards, and harnesses used for personal fall protection must be compatible with all connectors used.

(20) Ropes, belts, lanyards, lifelines, and harnesses used for personal fall protection must be protected from being cut, abraded, melted, or otherwise damaged.

(21) The employer must provide for prompt rescue of each employee in the event of a fall.

(22) Personal fall protection systems must be worn with the attachment point of the body harness located in the center of the employee's back near shoulder level. The attachment point may be located in the pre-sternal position if the free fall distance is limited to 2 feet (0.6 m) or less.

(d) Personal fall arrest systems--(1) System performance criteria. In addition to the general requirements in paragraph (c) of this section, the employer must ensure that personal fall arrest systems:

(i) Limit the maximum arresting force on the employee to 1,800 pounds (8 kN);

(ii) Bring the employee to a complete stop and limit the maximum deceleration distance the employee travels to 3.5 feet (1.1 m);

(iii) Have sufficient strength to withstand twice the potential impact energy of the employee free falling a distance of 6 feet (1.8 m), or the free fall distance permitted by the system; and

(iv) Sustain the employee within the system/strap configuration without making contact with the employee's neck and chin area.

(v) If the personal fall arrest system meets the criteria and protocols in appendix D of this subpart, and is being used by an employee having a combined body and tool weight of less than 310 pounds (140 kg), the system is considered to be in compliance with the provisions of paragraphs (d)(1)(i) through (iii) of this section. If the system is used by an employee having a combined body and tool weight of 310 pounds (140kg) or more and the employer has appropriately modified the criteria and protocols in appendix D, then the system will be deemed to be in compliance with the requirements of paragraphs (d)(1)(i) through (iii).

(2) System use criteria. The employer must ensure that:

(i) On any horizontal lifeline that may become a vertical lifeline, the device used to connect to the horizontal lifeline is capable of locking in both directions on the lifeline.

(ii) Personal fall arrest systems are rigged in such a manner that the employee cannot free fall more than 6 feet (1.8 m) or contact a lower level. A free fall may be more than 6 feet (1.8 m)

provided the employer can demonstrate the manufacturer designed the system to allow a free fall of more than 6 feet and tested the system to ensure a maximum arresting force of 1,800 pounds (8 kN) is not exceeded.

(3) Body belts. Body belts are prohibited as part of a personal fall arrest system.

(e) Positioning systems--(1) System performance requirements. The employer must ensure that each positioning system meets the following requirements:

(i) General. All positioning systems, except window cleaners' positioning systems, are capable of withstanding, without failure, a drop test consisting of a 4-foot (1.2-m) drop of a 250-pound (113-kg) weight;

(ii) Window cleaners' positioning systems. All window cleaners' positioning systems must:

(A) Be capable of withstanding without failure a drop test consisting of a 6-foot (1.8-m) drop of a 250-pound (113-kg) weight; and

(B) Limit the initial arresting force on the falling employee to not more than 2,000 pounds (8.9 kN), with a duration not exceeding 2 milliseconds and any subsequent arresting forces to not more than 1,000 pounds (4.5 kN).

(iii) Positioning systems, including window cleaners' positioning systems, that meet the test methods and procedures in appendix D of this subpart are considered to be in compliance with paragraphs (e)(1)(i) and (ii).

(iv) Lineman's body belt and pole strap systems. Lineman's body belt and pole strap systems must meet the following tests:

(A) A dielectric test of 819.7 volts, AC, per centimeter (25,000 volts per foot) for 3 minutes without visible deterioration;

(B) A leakage test of 98.4 volts, AC, per centimeter (3,000 volts per foot) with a leakage current of no more than 1 mA; and

(C) A flammability test in accordance with Table I-7 of this section.

Table I-7 -- Flammability Test

Test Method	Criteria for Passing Test
1. Vertically suspend a 19.7-inch (500-mm) length of strapping supporting a 220.5-lb (100-kg) weight; 2. Use a butane or propane burner with a 3-inch (76-mm) flame; 3. Direct the flame to an edge of the strapping at a distance of 1 inch (25mm); 4. Remove the flame after 5 seconds; and 5. Wait for any flames on the positioning strap to stop burning.	Any flames on the positioning strap must self-extinguish. The positioning strap must continue to support the 220.5-lb (100-kg) mass.

(2) System use criteria for window cleaners' positioning systems. The employer must ensure that window cleaners' positioning systems meet and are used in accordance with the following:

(i) Window cleaners' belts are designed and constructed so that:

(A) Belt terminals will not pass through their fastenings on the belt or harness if a terminal comes loose from the window anchor; and

(B) The length of the runner from terminal tip to terminal tip is 8 feet (2.44 m) or less;

(ii) Window anchors to which belts are fastened are installed in the side frames or mullions of the window at a point not less than 42 inches (106.7 cm) and not more than 51 inches (129.5 cm) above the window sill;

(iii) Each window anchor is capable of supporting a minimum load of 6,000 pounds (26.5 kN);

(iv) Use of installed window anchors for any purpose other than attaching the window cleaner's belt is prohibited;

(v) A window anchor that has damaged or deteriorated fastenings or supports is removed, or the window anchor head is detached so the anchor cannot be used;

(vi) Rope that has wear or deterioration that affects its strength is not used;

(vii) Both terminals of the window cleaner's belt are attached to separate window anchors during any cleaning operation;

(viii) No employee works on a window sill or ledge on which there is snow, ice, or any other slippery condition, or one that is weakened or rotted;

(ix) No employee works on a window sill or ledge unless:

(A) The window sill or ledge is a minimum of 4 inches (10 cm) wide and slopes no more than 15 degrees below horizontal; or

(B) The 4-inch minimum width of the window sill or ledge is increased 0.4 inches (1 cm) for every degree the sill or ledge slopes beyond 15 degrees, up to a maximum of 30 degrees;

(x) The employee attaches at least one belt terminal to a window anchor before climbing through the window opening, and keeps at least one terminal attached until completely back inside the window opening;

(xi) Except as provided in paragraph (e)(2)(xii) of this section, the employee travels from one window to another by returning inside the window opening and repeating the belt terminal attachment procedure at each window in accordance with paragraph (e)(2)(x) of this section;

(xii) An employee using a window cleaner's positioning system may travel from one window to another while outside of the building, provided:

(A) At least one belt terminal is attached to a window anchor at all times;

(B) The distance between window anchors does not exceed 4 feet (1.2 m) horizontally.

The distance between windows may be increased up to 6 feet (1.8 m) horizontally if the window sill or ledge is at least 1 foot (0.31 m) wide and the slope is less than 5 degrees;

(C) The sill or ledge between windows is continuous; and

(D) The width of the window sill or ledge in front of the mullions is at least 6 inches (15.2 cm) wide.

12. Add appendices C and D to subpart I of part 1910 to read as follows:

Appendix C to Subpart I of Part 1910 – Personal Fall Protection Systems Non-Mandatory Guidelines

The following information generally applies to all personal fall protection systems and is intended to assist employers and employees comply with the requirements of §1910.140 for personal fall protection systems.

(a) Planning considerations. It is important for employers to plan prior to using personal fall protection systems. Probably the most overlooked component of planning is locating suitable anchorage points. Such planning should ideally be done before the structure or building is constructed so that anchorage points can be used later for window cleaning or other building maintenance.

(b) Selection and use considerations. (1) The kind of personal fall protection system selected should be appropriate for the employee's specific work situation. Free fall distances

should always be kept to a minimum. Many systems are designed for particular work applications, such as climbing ladders and poles; maintaining and servicing equipment; and window cleaning. Consideration should be given to the environment in which the work will be performed. For example, the presence of acids, dirt, moisture, oil, grease, or other substances, and their potential effects on the system selected, should be evaluated. The employer should fully evaluate the work conditions and environment (including seasonal weather changes) before selecting the appropriate personal fall protection system. Hot or cold environments may also affect fall protection systems. Wire rope should not be used where electrical hazards are anticipated. As required by §1910.140(c)(21), the employer must provide a means for promptly rescuing an employee should a fall occur.

(2) Where lanyards, connectors, and lifelines are subject to damage by work operations, such as welding, chemical cleaning, and sandblasting, the component should be protected, or other securing systems should be used. A program for cleaning and maintaining the system may be necessary.

(c) Testing considerations. Before purchasing a personal fall protection system, an employer should insist that the supplier provide information about its test performance (using recognized test methods) so the employer will know that the system meets the criteria in §1910.140. Otherwise, the employer should test the equipment to ensure that it is in compliance. Appendix D to this subpart contains test methods which are recommended for evaluating the performance of any system. There are some circumstances in which an employer can evaluate a system based on data and calculations derived from the testing of similar systems. Enough information must be available for the employer to demonstrate that its system and the tested system(s) are similar in both function and design.

(d) Component compatibility considerations. Ideally, a personal fall protection system is designed, tested, and supplied as a complete system. However, it is common practice for lanyards, connectors, lifelines, deceleration devices, body belts, and body harnesses to be interchanged since some components wear out before others. Employers and employees should realize that not all components are interchangeable. For instance, a lanyard should not be connected between a body harness and a deceleration device of the self-retracting type (unless specifically allowed by the manufacturer) since this can result in additional free fall for which the system was not designed. In addition, positioning components, such as pole straps, ladder hooks and rebar hooks, should not be used in personal fall arrest systems unless they meet the appropriate strength and performance requirements of part 1910 (e.g., §§1910.140, 1910.268 and 1910.269). Any substitution or change to a personal fall protection system should be fully evaluated or tested by a competent person to determine that it meets applicable OSHA standards before the modified system is put in use. Also, OSHA suggests that rope be used according to manufacturer's recommendations, especially if polypropylene rope is used.

(e) Employee training considerations. As required by §§1910.30 and 1910.132, before an employee uses a fall protection system, the employer must ensure that he or she is trained in the proper use of the system. This may include the following: the limits of the system; proper anchoring and tie-off techniques; estimating free fall distance, including determining elongation and deceleration distance; methods of use; and inspection and storage. Careless or improper use of fall protection equipment can result in serious injury or death. Employers and employees should become familiar with the material in this standard and appendix, as well as manufacturers' recommendations, before a system is used. It is important for employees to be aware that certain tie-offs (such as using knots and tying around sharp edges) can reduce the overall strength of a

system. Employees also need to know the maximum permitted free fall distance. Training should stress the importance of inspections prior to use, the limitations of the equipment to be used, and unique conditions at the worksite that may be important.

(f) Instruction considerations. Employers should obtain comprehensive instructions from the supplier or a qualified person as to the system's proper use and application, including, where applicable:

- (1) The force measured during the sample force test;
- (2) The maximum elongation measured for lanyards during the force test;
- (3) The deceleration distance measured for deceleration devices during the force test;
- (4) Caution statements on critical use limitations;
- (5) Limits of the system;
- (6) Proper hook-up, anchoring and tie-off techniques, including the proper D-ring or other attachment point to use on the body harness;
- (7) Proper climbing techniques;
- (8) Methods of inspection, use, cleaning, and storage; and
- (9) Specific lifelines that may be used.

(g) Inspection considerations. Personal fall protection systems must be inspected before initial use in each workshift. Any component with damage, such as a cut, tear, abrasion, mold, or evidence of undue stretching, an alteration or addition that might affect its effectiveness, damage due to deterioration, fire, acid, or other corrosive damage, distorted hooks or faulty hook springs, tongues that are unfitted to the shoulder of buckles, loose or damaged mountings, non-functioning parts, or wear, or internal deterioration must be removed from service immediately, and should be tagged or marked as unusable, or destroyed. Any personal fall protection system,

including components, subjected to impact loading must be removed from service immediately and not used until a competent person inspects the system and determines that is not damaged and is safe to use for personal fall protection.

(h) Rescue considerations. As required by §1910.140(c)(21), when personal fall arrest systems are used, special consideration must be given to rescuing an employee promptly should a fall occur. The availability of rescue personnel, ladders, or other rescue equipment needs to be evaluated since there may be instances in which employees cannot self-rescue (e.g., employee unconscious or seriously injured). In some situations, equipment allowing employees to rescue themselves after the fall has been arrested may be desirable, such as devices that have descent capability.

(i) Tie-off considerations. Employers and employees should at all times be aware that the strength of a personal fall arrest system is based on its being attached to an anchoring system that can support the system. Therefore, if a means of attachment is used that will reduce the strength of the system (such as an eye-bolt/snaphook anchorage), that component should be replaced by a stronger one that will also maintain the appropriate maximum deceleration characteristics. The following is a listing of some situations in which employers and employees should be especially cautious:

(1) Tie-off using a knot in the lanyard or lifeline (at any location). The strength of the line can be reduced by 50 percent or more if a knot is used. Therefore, a stronger lanyard or lifeline should be used to compensate for the knot, or the lanyard length should be reduced (or the tie-off location raised) to minimize free fall distance, or the lanyard or lifeline should be replaced by one which has an appropriately incorporated connector to eliminate the need for a knot.

(2) Tie-off around rough or sharp (e.g. “H” or “I” beams) surfaces. Sharp or rough surfaces can damage rope lines and this reduces strength of the system drastically. Such tie-offs should be avoided whenever possible. An alternate means should be used such as a snaphook/D-ring connection, a tie-off apparatus (steel cable tie-off), an effective padding of the surfaces, or an abrasion-resistant strap around the supporting member. If these alternative means of tie-off are not available, the employer should try to minimize the potential free fall distance.

(3) Knots. Sliding hitch knots should not be used except in emergency situations. The one-and-one sliding hitch knot should never be used because it is unreliable in stopping a fall. The two-and-two, or three-and-three knots (preferable) may be used in emergency situations; however, care should be taken to limit free fall distances because of reduced lifeline/lanyard strength. OSHA requires that a competent or qualified person inspect each knot in a lanyard or vertical lifeline to ensure it meets the strength requirements in §1910.140.

(j) Horizontal lifelines. Horizontal lifelines, depending on their geometry and angle of sag, may be subjected to greater loads than the impact load imposed by an attached component. When the angle of horizontal lifeline sag is less than 30 degrees, the impact force imparted to the lifeline by an attached lanyard is greatly amplified. For example, with a sag angle of 15 degrees the force amplification is about 2:1, and at 5 degrees sag it is about 6:1. Depending on the angle of sag, and the line's elasticity, the strength of the horizontal lifeline, and the anchorages to which it is attached should be increased a number of times over that of the lanyard. Extreme care should be taken in considering a horizontal lifeline for multiple tie-offs. If there are multiple tie-offs to a horizontal lifeline, and one employee falls, the movement of the falling employee and the horizontal lifeline during arrest of the fall may cause other employees to fall. Horizontal lifeline and anchorage strength should be increased for each additional employee to

be tied-off. For these and other reasons, the systems using horizontal lifelines must be designed only by qualified persons. OSHA recommends testing installed lifelines and anchors prior to use. OSHA requires that horizontal lifelines are designed, installed and used under the supervision of a qualified person.

(k) Eye-bolts. It must be recognized that the strength of an eye-bolt is rated along the axis of the bolt, and that its strength is greatly reduced if the force is applied at right angles to this axis (in the direction of its shear strength). Care should also be exercised in selecting the proper diameter of the eye to avoid creating a roll-out hazard (accidental disengagement of the snaphook from the eye-bolt).

(l) Vertical lifeline considerations. As required by §1910.140(c)(3), each employee must have a separate lifeline when the lifeline is vertical. If multiple tie-offs to a single lifeline are used, and one employee falls, the movement of the lifeline during the arrest of the fall may pull other employees' lanyards, causing them to fall as well.

(m) Snaphook and carabiner considerations. As required by §1910.140(c)(10), the following connections must be avoided unless the locking snaphook or carabiner has been designed for them because they are conditions that can result in rollout:

- (1) Direct connection to webbing, rope, or a horizontal lifeline;
- (2) Two (or more) snaphooks or carabiners connected to one D-ring;
- (3) Two snaphooks or carabiners connected to each other;
- (4) Snaphooks or carabiners connected directly to webbing, rope, or wire rope; and
- (5) Improper dimensions of the D-ring, rebar, or other connection point in relation to the snaphook or carabiner dimensions which would allow the gate to be depressed by a turning motion.

(n) Free fall considerations. Employers and employees should always be aware that a system's maximum arresting force is evaluated under normal use conditions established by the manufacturer. OSHA requires that personal fall arrest systems be rigged so an employee cannot free fall in excess of 6 feet (1.8 m). Even a few additional feet of free fall can significantly increase the arresting force on the employee, possibly to the point of causing injury and possibly exceeding the strength of the system. Because of this, the free fall distance should be kept to a minimum, and, as required by §1910.140(d)(2), must never be greater than 6 feet (1.8 m). To assure this, the tie-off attachment point to the lifeline or anchor should be located at or above the connection point of the fall arrest equipment to the harness. (Otherwise, additional free fall distance is added to the length of the connecting means (i.e., lanyard)). Tying off to the walking-working surface will often result in a free fall greater than 6 feet (1.8 m). For instance, if a 6-foot (1.8-m) lanyard is used, the total free fall distance will be the distance from the walking-working level to the harness connection plus the 6 feet (1.8 m) of lanyard.

(o) Elongation and deceleration distance considerations. During fall arrest, a lanyard will stretch or elongate, whereas activation of a deceleration device will result in a certain stopping distance. These distances should be available with the lanyard or device's instructions and must be added to the free fall distance to arrive at the total fall distance before an employee is fully stopped. The additional stopping distance may be significant if the lanyard or deceleration device is attached near or at the end of a long lifeline, which may itself add considerable distance due to its own elongation. As required by §1910.140(d)(2), sufficient distance to allow for all of these factors must also be maintained between the employee and obstructions below, to prevent an injury due to impact before the system fully arrests the fall. In addition, a minimum of 12 feet (3.7 m) of lifeline should be allowed below the securing point of a rope-grab-type deceleration

device, and the end terminated to prevent the device from sliding off the lifeline. Alternatively, the lifeline should extend to the ground or the next working level below. These measures are suggested to prevent the employee from inadvertently moving past the end of the lifeline and having the rope grab become disengaged from the lifeline.

(p) Obstruction considerations. In selecting a location for tie-off, employers and employees should consider obstructions in the potential fall path of the employee. Tie-offs that minimize the possibilities of exaggerated swinging should be considered.

Appendix D to Subpart I of Part 1910 – Test Methods and Procedures for Personal Fall Protection Systems Non-Mandatory Guidelines

This appendix contains test methods for personal fall protection systems which may be used to determine if they meet the system performance criteria specified in paragraphs (d) and (e) of §1910.140.

Test methods for personal fall arrest systems (paragraph (d) of §1910.140).

(a) General. The following sets forth test procedures for personal fall arrest systems as defined in paragraph (d) of §1910.140.

(b) General test conditions.

(1) Lifelines, lanyards and deceleration devices should be attached to an anchorage and connected to the body harness in the same manner as they would be when used to protect employees.

(2) The fixed anchorage should be rigid, and should not have a deflection greater than 0.04 inches (1 mm) when a force of 2,250 pounds (10 kN) is applied.

(3) The frequency response of the load measuring instrumentation should be 120 Hz.

(4) The test weight used in the strength and force tests should be a rigid, metal cylindrical or torso-shaped object with a girth of 38 inches plus or minus 4 inches (96 cm plus or minus 10 cm).

(5) The lanyard or lifeline used to create the free fall distance should be supplied with the system, or in its absence, the least elastic lanyard or lifeline available should be used with the system.

(6) The test weight for each test should be hoisted to the required level and should be quickly released without having any appreciable motion imparted to it.

(7) The system's performance should be evaluated, taking into account the range of environmental conditions for which it is designed to be used.

(8) Following the test, the system need not be capable of further operation.

(c) Strength test.

(1) During the testing of all systems, a test weight of 300 pounds plus or minus 3 pounds (136.4 kg plus or minus 1.4 kg) should be used. (See paragraph (b)(4) of this appendix.)

(2) The test consists of dropping the test weight once. A new unused system should be used for each test.

(3) For lanyard systems, the lanyard length should be 6 feet plus or minus 2 inches (1.83 m plus or minus 5 cm) as measured from the fixed anchorage to the attachment on the body harness.

(4) For rope-grab-type deceleration systems, the length of the lifeline above the centerline of the grabbing mechanism to the lifeline's anchorage point should not exceed 2 feet (0.61 m).

(5) For lanyard systems, for systems with deceleration devices which do not automatically limit free fall distance to 2 feet (0.61 m) or less, and for systems with deceleration

devices which have a connection distance in excess of 1 foot (0.3 m) (measured between the centerline of the lifeline and the attachment point to the body harness), the test weight should be rigged to free fall a distance of 7.5 feet (2.3 m) from a point that is 1.5 feet (46 cm) above the anchorage point, to its hanging location (6 feet (1.83 m) below the anchorage). The test weight should fall without interference, obstruction, or hitting the floor or ground during the test. In some cases a non-elastic wire lanyard of sufficient length may need to be added to the system (for test purposes) to create the necessary free fall distance.

(6) For deceleration device systems with integral lifelines or lanyards that automatically limit free fall distance to 2 feet (0.61 m) or less, the test weight should be rigged to free fall a distance of 4 feet (1.22 m).

(7) Any weight that detaches from the harness should constitute failure for the strength test.

(d) Force test.

(1) General. The test consists of dropping the respective test weight specified in paragraph (d)(2)(i) or (d)(3)(i) of this appendix once. A new, unused system should be used for each test.

(2) For lanyard systems. (i) A test weight of 220 pounds plus or minus three pounds (100 kg plus or minus 1.6 kg) should be used. (See paragraph (b)(4) of this appendix.)

(ii) Lanyard length should be 6 feet plus or minus 2 inches (1.83 m plus or minus 5 cm) as measured from the fixed anchorage to the attachment on the body harness.

(iii) The test weight should fall free from the anchorage level to its hanging location (a total of 6 feet (1.83 m) free fall distance) without interference, obstruction, or hitting the floor or ground during the test.

(3) For all other systems. (i) A test weight of 220 pounds plus or minus 2 pounds (100 kg plus or minus 1.0 kg) should be used. (See paragraph (b)(4) of this appendix.)

(ii) The free fall distance to be used in the test should be the maximum fall distance physically permitted by the system during normal use conditions, up to a maximum free fall distance for the test weight of 6 feet (1.83 m), except as follows:

(A) For deceleration systems having a connection link or lanyard, the test weight should free fall a distance equal to the connection distance (measured between the centerline of the lifeline and the attachment point to the body harness).

(B) For deceleration device systems with integral lifelines or lanyards that automatically limit free fall distance to 2 feet (0.61 m) or less, the test weight should free fall a distance equal to that permitted by the system in normal use. (For example, to test a system with a self-retracting lifeline or lanyard, the test weight should be supported and the system allowed to retract the lifeline or lanyard as it would in normal use. The test weight would then be released and the force and deceleration distance measured).

(4) Failure. A system fails the force test when the recorded maximum arresting force exceeds 2,520 pounds (11.2 kN) when using a body harness.

(5) Distances. The maximum elongation and deceleration distance should be recorded during the force test.

(e) Deceleration device tests.

(1) General. The device should be evaluated or tested under the environmental conditions (such as rain, ice, grease, dirt, and type of lifeline) for which the device is designed.

(2) Rope-grab-type deceleration devices. (i) Devices should be moved on a lifeline 1,000 times over the same length of line a distance of not less than 1 foot (30.5 cm), and the mechanism should lock each time.

(ii) Unless the device is permanently marked to indicate the type of lifelines that must be used, several types (different diameters and different materials), of lifelines should be used to test the device.

(3) Other self-activating-type deceleration devices. The locking mechanisms of other self-activating-type deceleration devices designed for more than one arrest should lock each of 1,000 times as they would in normal service.

Test methods for positioning systems (paragraph (e) of §1910.140).

(a) General. The following sets forth test procedures for positioning systems as defined in paragraph (e) of §1910.140. The requirements in this appendix for personal fall arrest systems set forth procedures that may be used, along with the procedures listed below, to determine compliance with the requirements for positioning systems.

(b) Test conditions.

(1) The fixed anchorage should be rigid and should not have a deflection greater than 0.04 inches (1 mm) when a force of 2,250 pounds (10 kN) is applied.

(2) For window cleaners' belts, the complete belt should withstand a drop test consisting of a 250 pound (113 kg) weight falling free for a distance of 6 feet (1.83 m). The weight should be a rigid object with a girth of 38 inches plus or minus 4 inches (96 cm plus or minus 10 cm). The weight should be placed in the waistband with the belt buckle drawn firmly against the weight, as when the belt is worn by a window cleaner. One belt terminal should be attached to a rigid anchor and the other terminal should hang free. The terminals should be adjusted to their

maximum span. The weight fastened in the freely suspended belt should then be lifted exactly 6 feet (1.83 m) above its “at rest” position and released so as to permit a free fall of 6 feet (1.83 m) vertically below the point of attachment of the terminal anchor. The belt system should be equipped with devices and instrumentation capable of measuring the duration and magnitude of the arrest forces. Failure of the test should consist of any breakage or slippage sufficient to permit the weight to fall free of the system. In addition, the initial and subsequent arresting forces should be measured and should not exceed 2,000 pounds (8.5 kN) for more than 2 milliseconds for the initial impact, or exceed 1,000 pounds (4.5 kN) for the remainder of the arrest time.

(3) All other positioning systems (except for restraint line systems) should withstand a drop test consisting of a 250 pound (113 kg) weight free falling a distance of 4 feet (1.2 m). The weight must be a rigid object with a girth of 38 inches plus or minus 4 inches (96 cm plus or minus 10 cm). The body belt or harness should be affixed to the test weight as it would be to an employee. The system should be connected to the rigid anchor in the manner that the system would be connected in normal use. The weight should be lifted exactly 4 feet (1.2 m) above its “at rest” position and released so as to permit a vertical free fall of 4 feet (1.2 m). Failure of the system should be indicated by any breakage or slippage sufficient to permit the weight to fall free to the ground.

Subpart N—[Amended]

13. Revise the authority citation for subpart N to read as follows:

AUTHORITY: 29 U.S.C. 653, 655, 657; Secretary of Labor’s Order No. 12–71 (36 FR 8754), 8–76 (41 FR 25059), 9–83 (48 FR 35736), 1–90 (55 FR 9033), 6–96 (62 FR 111), 3–2000

(65 FR 50017), 5–2002 (67 FR 65008), 5–2007 (72 FR 31159), 4-2010 (75 FR 55355), or 1-2012 (77 FR 3912), as applicable; and 29 CFR part 1911.

14. In §1910.178, revise paragraph (j) to read as follows:

§1910.178 Powered industrial trucks.

* * * * *

(j) Dockboards (bridge plates). See subpart D of this part.

* * * * *

15. In §1910.179, revise paragraphs (c)(2), (d)(3), and (d)(4)(iii) to read as follows:

§1910.179 Overhead and gantry cranes.

* * * * *

(c) * * *

(2) Access to crane. Access to the car and/or bridge walkway shall be by a conveniently placed fixed ladder, stairs, or platform requiring no step over any gap exceeding 12 inches (30 cm). Fixed ladders must comply with subpart D of this part.

* * * * *

(d) * * *

(3) Toeboards and handrails for footwalks. Toeboards and handrails must comply with subpart D of this part.

(4) * * *

(iii) Ladders shall be permanently and securely fastened in place and constructed in compliance with subpart D of this part.

* * * * *

Subpart R—[Amended]

16. Revise the authority citation for subpart R to read as follows:

AUTHORITY: 29 U.S.C. 653, 655, 657; Secretary of Labor’s Order No. 12–71 (36 FR 8754), 8–76 (41 FR 25059), 9–83 (48 FR 35736), 1–90 (55 FR 9033), 6–96 (62 FR 111), 5–2007 (72 FR 31159), 4-2010 (75 FR 55355), or 1-2012 (77 FR 3912), as applicable; and 29 CFR part 1911.

17. In §1910.261, revise paragraphs (c)(15)(ii), (e)(4), (g)(2)(ii), (g)(13)(i), (h)(1), (j)(4)(iii), (j)(5)(i), (k)(6), (k)(13)(i) and (k)(15) to read as follows:

§1910.261 Pulp, paper, and paperboard mills.

* * * * *

(c) * * *

(15) * * *

(ii) Where conveyors cross passageways or roadways, a horizontal platform shall be provided under the conveyor, extended out from the sides of the conveyor a distance equal to 1 1/2 times the length of the wood handled. The platform shall extend the width of the road plus 2 feet (61 cm) on each side, and shall be kept free of wood and rubbish. The edges of the platform shall be provided with toeboards or other protection that meet the requirements of subpart D of this part, to prevent wood from falling.

* * * * *

(e) * * *

(4) Runway to the jack ladder. The runway from the pond or unloading dock to the table

shall be protected with standard handrails and toeboards. Inclined portions shall have cleats or equivalent nonslip surfacing that complies with subpart D of this part. Protective equipment shall be provided for persons working over water.

* * * * *

(g) * * *

(2) * * *

(ii) The worker shall be provided with eye protection, a supplied air respirator and a personal fall protection system that meets the requirements of subpart I of this part, during inspection, repairs or maintenance of acid towers. The line shall be extended to an attendant stationed outside the tower opening.

* * * * *

(13) * * *

(i) Blow-pit openings preferably shall be on the side of the pit instead of on the top. Openings shall be as small as possible when located on top, and shall be protected in accordance with subpart D of this part.

* * * * *

(h) * * *

(1) Bleaching engines. Bleaching engines, except the Bellmer type, shall be completely covered on the top, with the exception of one small opening large enough to allow filling, but too small to admit an employee. Platforms leading from one engine to another shall have standard guardrails that meet the requirements in subpart D of this part.

* * * * *

(j) * * *

(4) * * *

(iii) When beaters are fed from the floor above, the chute opening, if less than 42 inches (1.06 m) from the floor, shall be provided with a guardrail system that meets the requirements in subpart D of this part, or other equivalent enclosures. Openings for manual feeding shall be sufficient only for entry of stock, and shall be provided with at least two permanently secured crossrails or other fall protection system that meet the requirements in subpart D.

* * * * *

(5) * * *

(i) All pulpers having the top or any other opening of a vessel less than 42 inches (107 cm) from the floor or work platform shall have such openings guarded by guardrail systems that meet the requirements in subpart D of this part, or other equivalent enclosures. For manual changing, openings shall be sufficient only to permit the entry of stock, and shall be provided with at least two permanently secured crossrails, or other fall protection systems that meet the requirements in subpart D.

* * * * *

(k) * * *

(6) Steps. Steps of uniform rise and tread with nonslip surfaces that meet the requirements in subpart D of this part shall be provided at each press.

* * * * *

(13) * * *

(i) A guardrail that complies with subpart D of this part shall be provided at broke holes.

* * * * *

(15) Steps. Steps or ladders that comply with subpart D of this part and tread with

nonslip surfaces shall be provided at each calendar stack. Handrails and hand grips complying with subpart D shall be provided at each calendar stack.

* * * * *

18. In §1910.262, revise paragraph (r) to read as follows:

§1910.262 Textiles.

* * * * *

(r) Gray and white bins. On new installations guardrails that comply with subpart D of this part shall be provided where workers are required to plait by hand from the top of the bin so as to protect the worker from falling to a lower level.

* * * * *

19. In §1910.265, revise paragraphs (c)(4)(v), (c)(5)(i), and (f)(6) to read as follows:

§1910.265 Sawmills.

* * * * *

(c) * * *

(4) * * *

(v) Elevated platforms. Where elevated platforms are used routinely on a daily basis, they shall be equipped with stairways or fixed ladders that comply with subpart D of this part.

* * *

(5) * * *

(i) Construction. Stairways shall be constructed in accordance with subpart D of this part.

* * * * *

(f) * * *

(6) Ladders. A fixed ladder complying with the requirements of subpart D of this part, or other adequate means, shall be provided to permit access to the roof. Where controls and machinery are mounted on the roof, a permanent stairway with standard handrail shall be installed in accordance with the requirements in subpart D.

* * * * *

20. In §1910.268:

- a. Revise paragraphs (g)(1);
- b. Remove paragraph (g)(2);
- c. Redesignate (g)(3) as (g)(2); and
- d. Revise paragraph (h).

The revisions read as follows:

§1910.268 Telecommunications.

* * * * *

(g) Personal climbing equipment—(1) General. A positioning system or a personal fall arrest system shall be provided and the employer shall ensure their use when work is performed at positions more than 4 feet (1.2 m) above the ground, on poles, and on towers, except as provided in paragraphs (n)(7) and (8) of this section. These systems shall meet the applicable requirements in subpart I of this part. The employer shall ensure that all climbing equipment is inspected before each day's use to determine that it is in safe working condition.

* * * * *

(h) Ladders. Ladders, step bolts, and manhole steps shall meet the applicable requirements in subpart D of this part.

* * * * *

21. In §1910.269, revise paragraphs (g)(2)(i), (g)(2)(iv)(B), and (g)(2)(iv)(C)(1) to read as follows:

§1910.269 Electric power generation, transmission, and distribution.

* * * * *

(g) * * *

(2) * * *

(i) Personal fall arrest systems shall meet the requirements of subpart I of this part.

* * * * *

(iv) * * *

(B) Personal fall arrest systems shall be used in accordance with subpart I of this part.

Note to paragraph (g)(2)(iv)(B): Fall protection equipment rigged to arrest falls is considered a fall arrest system and must meet the applicable requirements for the design and use of those systems. Fall protection equipment rigged for work positioning is considered work-positioning equipment and must meet the applicable requirements for the design and use of that equipment.

(C) * * *

(1) Each employee working from an aerial lift shall use a travel restraint system or a personal fall arrest system.

* * * * *

BILLING CODE 4510-29-P