



**Cal/OSHA, DOT HAZMAT, EEOC,  
EPA, HAZWOPER, HIPAA, IATA,  
IMDG, TDG, MSHA, OSHA, and  
Canada OHS Regulations and  
Safety Online Training**

**Since 2008**

This document is provided as a training aid  
and may not reflect current laws and regulations.

Be sure and consult with the appropriate governing agencies  
or publication providers listed in the "Resources" section of our website.

[www.ComplianceTrainingOnline.com](http://www.ComplianceTrainingOnline.com)



[Facebook](#)



[LinkedIn](#)



[Twitter](#)



[Website](#)

## EMERGENCY EYEWASH EQUIPMENT

Accidental exposure of the eyes to chemical substances in any form can result in irritation, temporary or permanent vision impairment, or blindness.

The provision of engineering controls and personal eye protection that minimize the possibility of eye exposure to harmful chemical substances is the best protection against eye injury in the workplace. To supplement these, the availability of proper emergency equipment for the treatment of eyes exposed to hazardous substances is an essential safety precaution.

Under the Workplace Safety and Health Act, an employer is required to provide approved emergency eyewash equipment, in conjunction with effective eye protection programs in any workplace where there is a risk of eye injury from exposure to hazardous chemical substances. Such emergency eyewash equipment must meet the requirements identified in the American National Standards Institute (ANSI) Standard for Emergency Eyewash and Shower Equipment Z358.1.

ANSI approved emergency eyewash equipment is designed to function quickly and effectively under a set of typical circumstances. When a person's eyes are accidentally exposed to a hazardous chemical substance, the following is likely to occur:

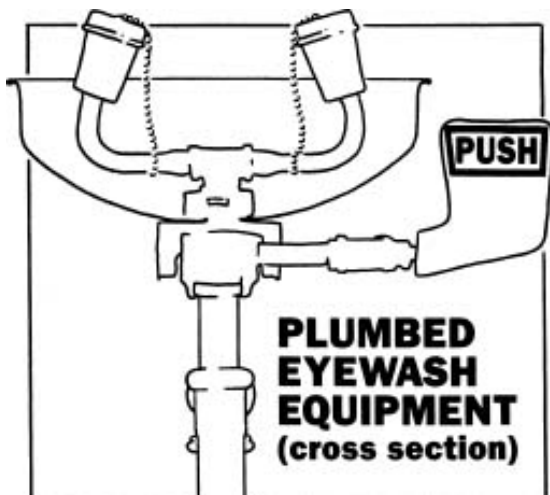

- ◆ A degree of panic may set in and the person will not always think or react in a clear fashion;
- ◆ Vision is immediately impaired, so that the person cannot clearly see where they are going or what they are doing;
- ◆ Assistance may not be immediately available.

Regardless of the situation or circumstance, emergency treatment must be available immediately. Every second lost could lead to permanent damage. Proper emergency eyewash equipment could save someone's eyesight.



**Requirements:**

- ◆ The water in the eyewash station shall be potable (drinkable).
- ◆ A controlled flow of water must be provided to both eyes simultaneously at a velocity low enough not to be injurious to the user.
- ◆ There shall be no sharp projections anywhere in the operating area of the unit.
- ◆ Nozzles shall be protected from airborne contaminants. The removal of such protection shall not require a separate motion by the operator when activating the unit.
- ◆ The control valve shall be:
  - capable of being quickly located and operated; and
  - **capable of being fully activated in one second or less** and designed to remain on until intentionally shut off.
- ◆ The eyewash unit shall be in an accessible location as close to the hazard as possible, and **require no greater than 10 seconds to reach.**
- ◆ The eyewash unit shall be identified with a highly visible sign. The area around or behind, or both, shall be painted a bright color.
- ◆ Water nozzles shall be positioned between 83.8 cm (33 inches) and 114.3 cm (45 inches) from the floor.
- ◆ Plumbed eyewash units shall be activated weekly to flush the line and verify proper operation. Self-contained units shall be inspected according to manufacturers' specification.
- ◆ All employees who may be exposed to eye injury shall be instructed in the proper use of emergency eyewash units.
- ◆ Outdoor units shall be freeze protected.
- ◆ Tepid water temperature in units must not exceed 38 degrees C (100 degrees F). A medical advisor should be consulted for optimum temperature for each application.

***Note: Personal eyewash equipment, such as squeeze bottles, can support but not replace proper eyewash stations. The first few seconds following an eye injury are often critical to keeping injury to a minimum. A personal eyewash unit may be kept in the immediate vicinity of employees working in a potentially hazardous area. The main purpose of these units is to supply immediate flushing. With this accomplished, the injured individual should then proceed to a plumbed or self-contained eyewash and flush the eyes for the required 15-minute period. Material Safety Data Sheets (MSDS) should be consulted for additional recommendations.***

***Approved eyewash units may be part of eye-facewash and/or emergency shower units. Depending on the types of hazards present, these options may be preferable to single purpose eyewash units.***