



COMPLIANCE TRAINING
ONLINE.com

Cal/OSHA, DOT HAZMAT, EEOC, EPA, HIPAA, IATA, IMDG, TDG, MSHA, OSHA, Australia WHS, and Canada OHS Regulations and Safety Online Training

This document is provided as a training aid
and may not reflect current laws and regulations.

Be sure and consult with the appropriate governing agencies
or publication providers listed in the "Resources" section of our website.

www.ComplianceTrainingOnline.com



[Facebook](#)



[LinkedIn](#)



[Twitter](#)



[Google Plus](#)



[Website](#)

Electrical Safety Testing Reference Guide



5 Clock Tower Place, 210 East, Maynard, Massachusetts 01754
TELE: (800) 253-1230, FAX: (978) 461-4295, INTL: (978) 461-2100

[http:// www.quadtech.com](http://www.quadtech.com)

Preface

In the electrical product business, product safety compliance is an important issue for several reasons. Manufacturers and distributors want to sell “safe products”. Consumers want to buy products with the assurance that they won’t be exposed to hazards. Product quality, reliability, user safety and company liability issues are real consequences of doing business today.

Regardless of your specific interest in safety testing, it is important for you to have a general understanding of product safety requirements and how they affect your device. Needed as well is an overall view of the regulatory compliance world and the specific steps in the process that may have a direct impact on your daily responsibilities.

The intent of this reference guide is to explain the need for and the basis of Electrical Safety Testing (EST). This guide provides a general overview of the regulatory framework and approval process and explores the specific manufacturing responsibilities and test procedures associated with electrical safety testing.



5 Clock Tower Place, 210 East
Maynard, Massachusetts 01754
Tele: (800) 253-1230
Fax: (978) 461-4295
Intl: (978) 461-2100
Web: <http://www.quadtech.com>

The material in this guide is for informational purposes only and is subject to change without notice. QuadTech assumes no responsibility for any error or for consequential damages that may result from the misinterpretation of any content in this publication.

Contents

Preface	3	Accessory Equipment	33
Overview	5	Tester Calibration	33
Product Safety	5	NIST Standards	33
Electrical Shock	5	120 Kohm Leakage Impedance	33
Worldwide Regulatory Compliance	6	Tester Applications	34
United States	6	Appliance Testing	34
Canada	7	Motor Testing	34
European Union	7	Transformer Testing	35
Typical Product Safety Standards	9	Electrical Component Testing	36
Standards in the News	10	Examples of High Performance Testers	37
Compliance Tests	11	Sentry Series Testers	37
Production Line Testing	11	S 10/15 AC Hipot Tester	37
Dielectric Strength	12	S 20/25 AC/DC Hipot Tester	37
Insulation Resistance	12	S 30/35 AC/DC/IR Hipot Tester	37
Leakage Current Tests	12	S50 Ground Bond Tester	37
Ground Continuity	13	Guardian Series Testers	38
Ground Bond	13	Common Features	38
Product Safety Tests	14	Guardian 1000 Series	
Dielectric Strength Tests	14	G 1010 AC Hipot Tester	38
AC or DC	14	G 1030 AC/DC/IR Hipot Tester	38
AC Hipot Tests	15	G 1030S AC/DC/IR/SC Hipot Tester	38
DC Hipot Tests	15	Guardian 2000 Series	
Arcing	16	G 2510 AC Hipot Tester	38
Line Regulation	17	G 2520 AC/DC Hipot Tester	38
Load Regulation	17	G 2530 AC/DC/IR Hipot Tester	38
Ramping	18	Guardian 6000 Series	
Min/Max Current Detection	18	G 6000 Electrical Safety Analyzer	39
Ground Continuity Test	18	G 6100 Production Safety Analyzer	39
Polarization Test	19	G 6200 Production Safety Analyzer	39
Ground Bond Test	19	Guardian Specialty Series	
Insulation Resistance Test	20	G 500VA AC/DC/IR Hipot Tester	40
Measurement Procedure	21	G 10kV AC Hipot Tester	40
Dielectric Absorption	21	G 12kV DC/IR Hipot Tester	40
Charging Current	21	Dedicated Function Test Instruments	41
Leakage Current	21	Milliohmmeters	41
Leakage Current Test	22	Megohmmeters	41
What is a Safe Level of Leakage?	23	Digibridge © Component Testers	41
Class I	23	Precision LCR Meters	41
Class II	23	Appendix A	43
Measurement of Leakage Current	23	Nationally Recognized Testing Laboratories (NRTLs) and Standards Organizations	44
Operator Safety	26	Product Safety Standards	45
Tester Environment	26	Typical Test Values: Product Safety Tests	47
Operator Training	28	Application Note Directory	49
Testing Guidelines/Procedures	28	Glossary	53
Test Equipment	29		
Choosing the Right Tester	29		
Recommended Tester Features	30		
General Tester Features	30		
Production Tester Features	31		

Overview

Product Safety

Making a product “safe” requires an understanding of the “hazards” that exist in each electrical product. Certain potential hazards are inherent in all electrical products because of the manner in which they are powered and how they perform their intended functions. Even though a product requires an electrical power source and uses electrical or electronic components, it should not present an electrical shock hazard to the user.

Four fundamental hazards must be evaluated as part of any product safety evaluation:

- Electrical shock
- Mechanical/physical injury
- Low voltage/high energy
- Fire

Specifications that address these hazards are contained in every product safety standard. Although additional safety requirements are also included in most safety standards, these four hazards are the foundation upon which all safety standards are based. This guide is only concerned with electrical safety testing methods. It focuses only on the tests and equipment needed to minimize electrical shock and does not discuss mechanical/physical injury and fire hazards.

Electrical Shock

Electrical shock and its effects can be caused and influenced by several factors. The primary effect is the result of electrical current passing through the human body. Severity of the injury to the human body is directly affected by such variables as: the nature of the electrical voltage (AC vs. DC); the pathway through the human body; conductivity of the contact (wet or dry); the size and shape of the individual involved i.e., the person’s impedance), duration of the contact, and the size of the contact area. All these affect the magnitude of current that flows through the person’s body.

Example:

Picture yourself in the bathroom with one hand in a sink full of water. As you grab for a towel behind you, the hair dryer (which is plugged in) falls into the sink. Your other hand contacts the grounded cold water faucet. You have placed yourself in the path of current flowing from the electrical outlet in which the hair dryer is plugged. The pathway, which is directly through your chest cavity, is likely to cause ventricular fibrillation. (Fibrillation occurs when the electrical pulses controlling your heart rate go into an uncontrollable pulsation, which prevents your heart from pumping properly, causing blood pressure to drop, eventually shutting down all bodily functions.)

It is difficult to set standards that protect users from all possible fault conditions, but many requirements have been established to provide fundamental levels of user safety. The previous example is the reason GFCI (ground fault current interrupters) are required by the National Electrical Code in wet locations. Such devices automatically interrupt power when a ground current larger than 5 mA exists for more than a few milliseconds. These devices have saved countless people from being electrocuted in their own homes.

The frequency in Hertz (Hz); i.e, cycles per second, of the electrical source is also a determining factor in the subsequent effect and/or reaction of the human body when subjected to electrical current flow. Studies have shown that low frequency voltages, such as AC power line voltage (50/60Hz) which is commonly found in the household or workplace, have a more immediate and damaging effect than DC voltage when contact with the human body occurs. Therefore, it is important that electrical products and appliances be designed to protect the user from contact with AC line/primary voltage.

Most safety standards address this issue by incorporating requirements that mandate appropriate product enclosures: connectors that do not allow direct user access, good dielectric or insulating barriers, as well as very low leakage current. Not all voltage potentials, however, are considered hazardous. Some are considered safe for user contact because of the low levels at which they operate. Since the standards are very specific about these limits, manufacturers must be careful to test their products against the right product standard to be sure that the products are safe.

Electrical shock hazards can be prevented by the following types of tests:

1. Dielectric Withstand (Hipot) Tests
2. Insulation Resistance Tests
3. Leakage Current Tests
4. Ground Continuity Tests

A *hipot test* measures the ability of a product to withstand a high voltage applied between the circuits of a product and ground.

An *insulation resistance test* measures the quality of the electrical insulation used in a product.

A *leakage current test* checks that the current that flows between AC source and ground does not exceed a safe limit.

A *ground continuity test* checks that a path exists between all exposed conductive metal surfaces and the power system ground.

Each of these tests is described in detail later in this document.

Worldwide Regulatory Compliance

In the field of product safety and product safety standards, significant change has taken place in the last ten years. Emphasis has been placed on the worldwide harmonization of product safety standards with the hope of establishing truly uniform global specifications. Although more progress needs to be made, results to date have been encouraging. Standards today are more closely coordinated than ever before.

Manufacturers need to know and understand the safety standards that apply to their particular products. It is equally important for them to have a full grasp of the whole field of product safety regulation.

In an attempt to provide a basic explanation of the regulatory process, how it works, and why you must comply, let's look at three of the major marketplaces, the United States, Canada, and the European Union (EU).

United States

In the U.S., regulatory requirements and federal laws are found in the Code of Federal Regulations. In this Code (CFR21-1910, Subpart S), you will find regulations for product safety approvals of electrical devices. The mandatory federal requirements specify that all electrical appliances and devices be "listed" by a Nationally Recognized Testing Laboratory (NRTL) for the purpose in which they will be used. The term "listed" means controlled, monitored, and otherwise placed under formal surveillance by the approval agency or testing laboratory. The term "NRTL" now applies to many laboratories operating under OSHA (Occupational Safety and Health Administration) accreditation for the purpose of carrying out product safety approvals according to accepted standards. For a current list of leading NRTLs, refer to Appendix A.

A listed product is commonly identified by the testing laboratory's listing mark (UL, ETL, MET, FM, etc.) conspicuously attached to the product. This listing mark indicates that the device manufacturer has submitted a sample to the laboratory for product safety test and evaluation in accordance with the relevant product safety standard. Once the NRTL finds the product fully complies with the standard, it grants the manufacturer permission to affix the agency listing label to the products. In the U.S., product safety certifications are generally carried out in accordance with the UL or IEC standards. As hundreds of standards exist, it is highly likely

that at least one of these safety standards applies to your product.

Canada

Canadian requirements parallel those of the United States. Enforcement of the Canadian regulations is primarily the responsibility of the hydroelectric authority inspectors and/or customs officials within each province. Electrical products are considered compliant if they bear the certification mark from a testing laboratory which has obtained accreditation as a Certification Organization, and if the certification was performed in accordance with the Canadian National Standards, commonly called the "CSA" standards. A laboratory obtains status as a Certification Organization by passing an examination conducted by the Standards Council of Canada (SCC). The SCC is similar to, but not identical with, OSHA in the United States.

Within the Canadian system, a Certification Organization or "CO" is viewed in a manner similar to that of an NRTL within the U.S. system. Presently, several laboratories have obtained the status of both a U.S. NRTL as well as a Canadian CO. Therefore, you can, in many cases, obtain both a U.S. Listing and Canadian Certification from one laboratory. As in the U.S., factory surveillance and production line testing are also required steps in the approval process.

European Union

The European Community (EC) was established to create an overall economic environment conducive to economic growth. A key mechanism for doing so was to establish community-wide standards for product safety. This resulted in the issuance of the Low-Voltage Directive 73/23/EEC and the EMC Directive 89/336/EEC.

The EMC Directive 89/336/EEC defines the requirements for handling electromagnetic disturbances created by a device as well as similar disturbances which could affect proper oper-

ation of the device. It also deals with tests such as ESD and emissions.

The Low Voltage Directive provides the framework and procedures for determining the product safety compliance of a wide variety of electrical devices and covers dielectric, ground continuity, and numerous other safety tests. The main focus of this reference guide is the Low Voltage Directive which was adopted in 1973 and with which most electrical products designed for sale in the EC (European Community) must comply.

Before the adoption of the Low-Voltage Directive, products had to be tested in accordance with the appropriate standard for each country and by an approved test laboratory for that country. Having to meet all of these and national standards adversely affected manufacturers who wanted to market products in Europe because of the expense of testing to the various standards without significantly improving product safety. The Low Voltage and EMC directives are official legislation of the European Union and, as such, supersede any existing national regulations. Member countries within the EU must adopt and enforce the directives.

The Low Voltage directive does not specifically state which electrical tests are required for compliance, but instead indicates that products being sold in the EC must be constructed according to good engineering principles and should provide adequate safety so as to not endanger the user of the product. In addition, it states that appropriate standards for the product being tested must continue to be followed and that it is the responsibility of the European Union to periodically select so-called harmonized standards. The harmonized standards are typically IEC standards or standards published by the European Committee for Electrotechnical Standardization (CENELEC) which may actually be derived from IEC standards. Table 1 shows some of the more common harmonized standards.

Table 1: Harmonized Standards for European Union Countries

Standard	Description
EN 50091	Un-interruptible Power System (UPS)
EN 50144	Safety of Hand-Held Electric Motor Operated Tools
EN 60034	Rotating Electrical Machines
EN 60065	Household Electronic Equipment
EN 60204	Safety of Machinery
EN 60335	Household Appliances
EN 60950	Safety of Information Technology Equipment including Electrical Business Equipment
EN 60967	Safety of Electrically Heated Blankets, Pads & Similar Flexible Heating Appliances for Households
EN 60968	Self Ballasted Lamps
EN 61010	Safety Requirements for Electrical Equipment for Measurement, Control and Laboratory
EN 60601	Medical and Dental Equipment

Table 2: Published UL/CSA BiNational/Harmonized Standards

UL Standard	CSA Standard	Description
UL 250	C22.2 No. 63	Household Refrigerators and Freezers
UL 749	C22.2 No. 167	Household Dishwashers
UL 998	C22.2 No. 104	Humidifiers
UL 1017	C22.2 No. 243	Vacuum Cleaners, Blower Cleaners, and Household Floor Finishing Machines
UL 1598	C22.2 No. 250.0	Luminaries
UL 1995	C22.2 No. 236	Heating and Cooling Equipment
UL 2157	C22.2 No. 169	Electric Clothes Washing Machines and Extractors
UL 2158	C22.2 No. 112	Electric Clothes Dryers
UL 60950	C22.2 No. 60950	Information Technology Equipment

Table 3: Published UL/IEC Harmonized Standards

Standard	Description
UL 2279	Electrical Equipment for Use in Class I, Zone 0, 1, and 2 Hazardous (Classified) Locations
UL 2601-1	Medical Electrical Equipment; Part 1: General Requirements
UL 3101-1	Electrical Equipment for Laboratory Use; Part 1: General Requirements
UL 3101-2-20	Electrical Equipment for Laboratory Use; Part 2: Laboratory Centrifuges
UL 3111-1	Electrical Measuring and Test Equipment; Part 1: General Requirements
UL 6500	Audio/Video and Musical Instrument Apparatus for Household, Commercial, and Similar General Use
UL 60335-1	Household & Similar Electrical Appliances, Part 1: General Requirements
UL 60335-2-34	Household & Similar Electrical Appliances, Part 2: Particular Requirements for Motor-Compressors
UL 60950	Information Technology Equipment

If a harmonized standard does not exist for the specific product being tested, the IEC or CENELEC standard covering that product is presumed to apply. If there is no IEC or CENELEC standard that covers the product, the national standards from the individual countries would

apply, such as BEAB Document 40. Manufacturers can, if they wish, test their products to various national standards in addition to testing the products to the applicable harmonized standard.

An example of one such harmonized standard is BS EN 61010-1: 1993 Safety Requirements for Electrical Equipment for Measurement, Control and Laboratory Use, Part 1: General Requirements. This standard published by CENELEC, is derived from IEC 1010-1, and specifies both design and routine production tests. The design tests are performed on a sample of products during initial design. Results from these tests must be available in a file for inspection. In addition to testing during the initial design phase, routine production tests are also required. The production tests, which are typically a subset of the design tests, usually include dielectric strength (hipot) and ground bond or ground continuity tests.

If the product passes all required tests, the Declaration of Conformity is completed and the product can be CE marked or labeled to show proof of compliance with the Low Voltage Directive. The Declaration of Conformity is normally a one page document that details the applicable directives and standards used to ensure full compliance. The Declaration must be completed before the CE marking can be applied. It must include the manufacturer's name, full address, model numbers, product identification, applicable electrical ratings, full details of technical standards used to perform the evaluation, and the signature of an authorized representative of the company.

Up to January 1, 1995, manufacturers demonstrated compliance with the Low Voltage Directive by issuing the Declaration of Conformity with each product. The Low Voltage Directive was amended effective January 1, 1995 to incorporate the CE Marking of products. An interim period was allowed between January 1, 1995 and January 1, 1997 for manufacturers to switch over to CE Marking of all products marketed in the EC. This means that, since January 1, 1997, all products covered under the Low Voltage Directive have to bear the CE Mark or label as proof that the product

complies with the directive. Note that the CE Mark indicates compliance, but does not provide specifics. The Declaration of Conformity provides the details of the regulatory compliance testing process.

Typical Product Safety Standards

Underwriters Laboratories (UL) produces a catalog of Standards for Safety that covers most products being sold today. This catalog contains listings of standards both by standard number as well as by key title words such as dishwashers, electric ranges etc. UL standards (as with most other standards) are developed by committees comprised of individuals from industry, academia, test laboratories and consumer groups. Each standard developed by a committee contains the basic requirements for the product being tested. The requirements set forth in the standard are based upon sound engineering principles, research, and experience in the field and represent the minimum requirements that the product must comply with to be UL marked. It is important to note that the ultimate responsibility for product safety is the manufacturer, not the standard. Compliance with the standard does not fully protect the manufacturer from liability and, conversely, compliance with the text of the standard does not mean the product will comply with the standard should examination of the product reveal a design which compromises safety.

The content of each standard can be divided into the following Sections: Introduction, Construction, Performance, Manufacturing and Production Tests, Markings and Appendix.

The [introduction](#) gives a basic overview of the standard and any other standards to which this standard may reference. The main focus is to outline what products are covered in the standard. This section will also provide an introduction to any terms and units of measure what will be used in later sections.

All aspects of [product construction](#) and assembly related to safety are dealt with in the section on construction. The focus is to insure that the product has been well manufactured and is acceptable from a safety standpoint. Minimum specifications are outlined for the frame, enclosure, and mechanical assembly to the spacing and requirements of electrical components. The design is also reviewed for protection against personal injury. When it comes to consumer products, the section on protection against personal injury is very extensive.

The section on [performance/ compliance](#) covers all of the various tests that need to be performed during initial product evaluation. This section will focus on the four types of safety requirements: shock, fire, energy and mechanical hazards as they pertain to the safety of an operator of the product. The performance tests verify that the manufacturer has followed the requirements laid out in the section on construction. Performance tests are generally extensive and cover operation of the product under normal and under fault conditions such as overload, product endurance, mechanical impacts to the enclosure, effect of moisture and humidity, and electrical safety tests such as leakage current, dielectric withstand, ground continuity, and ground bond.

The tests that must be performed on all products on an on going basis are outlined in the [manufacturing and production tests](#) section. The production tests are a subset of the performance tests and are generally less stringent. Production tests always include a dielectric withstand test, polarization, and ground continuity or ground bond. Note that ground continuity and ground bond tests are only applicable to products with a three-prong power cord. Medical products will also include a leakage current test. The required production test voltages and limits are outlined or referenced back to a performance test requirement. To ensure continued compliance, regular surveillance is

required in the form of quarterly factory inspections.

The section on [markings](#) will cover required terms and information that must be in the instruction manual and on the product and product carton. An example of the statements that are required in the instruction manual on appliances is "IMPORTANT SAFEGUARDS", "Read all instructions", "Avoid contacting moving part" and "SAVE THESE INSTRUCTIONS" to name just a few. Have you ever wondered why all of the appliance manuals seemed the same? Now you know why right down to the minimum size for the letters, which is also clearly spelled out.

[Standards In The News:](#)

UL 1950/ 60950 CSA C22.2 No. 950

[UL 1950](#) is a safety standard covering Information technology equipment including electrical business equipment and associated equipment, with a rated voltage not exceeding 600V. It also applies to equipment, which will be connected directly to a Telecommunication Network regardless of the power source.

UL 1950 current version is the third edition. The basic difference between the second and third edition is the creepage, clearance and spacing requirement in the power supply area. UL 1950 is essentially the same standard as IEC 950 and 60950.

April 1, 2005, [UL 60950](#) 3rd edition will eliminate and replace UL 1950 as the evaluation standard for Information Technology Equipment. This is a new Bi-National standard for United States and Canada Safety of Information Technology Equipment. UL 1950 has been changed to UL 60950 to correlate with the latest IEC standard, IEC 60950, third edition.

[Electrical strength](#) is one of the tests outlined in the standard. It is performed after humidity treatment, abnormal tests, impact tests and heating tests. The standard requires the elec-

trical strength of insulating materials used within the equipment is adequate. For a line voltage of 120 VAC, a basic insulation test would apply 1000 VAC or 1414 VDC to the tied together mains supply and ground. For 230 VAC, 1500 VAC would be applied or 2121 VDC. The voltage is ramped up until the test voltage is reached; the voltage is then held for 60 seconds. There should be no breakdown during the test. Insulation breakdown occurs when the current flow increases rapidly because the insulation is not restricting the current.

Ground Bond or Earth Continuity is also a necessary test. This test is carried out under high current, simulating a fault to earth. The standard requires that the resistance between protective earth and any conductive surface on the equipment does not exceed 0.1 ohm. The test is performed by applying an AC or DC current between the conductive surface and protective earth. The resistance is calculated by measuring the voltage drop. For circuits with a current rating 16 A or less, the test current is 1.5 times the current rated of the circuit under test and the test voltage is no greater than 12 V. The test is to last for 60 seconds and the resistance shall not exceed 0.1 ohms. For circuits with a current rating more than 16A the test current is twice the current rating of the circuit and tested for two minutes. The voltage drop shall not go above 2.5V.

Touch current also known, as earth leakage current must be within specified limits for its Class. In general, a Class I product has a 3-prong power cord and a Class II product has a 2-prong power cord. Refer to the Glossary for a full definition. For Class I equipment, the earth leakage current is the current that flows in the earth supply conductor during normal operation of the equipment. For Class II equipment, leakage is measured to earth from accessible conductive parts of the enclosure. If no conductive parts are exposed a "hand sized" piece of metal foil is placed on the enclosure.

This measurement is performed by opening the ground conductor, inserting a circuit with the simulated impedance of the human body and measuring the voltage across part of the circuit with a true RMS voltmeter. The Maximum leakage for Handheld Class I equipment is 0.75mA, for all other Class I equipment 3.5mA and for Class II equipment 0.25mA.

Compliance Tests

Product safety standards contain three primary sets of requirements: (1) constructional specifications related to parts and the methods of assembling, securing, and enclosing the device and its associated components, (2) performance specifications or "type tests" - the actual electrical and mechanical tests to which the test sample is subjected, and (3) production and manufacturing tests which are required on all products. These tests are generally a subset of the performance test. The test methods and the pass/fail limits were established as a basis of providing a margin of safety in cases of misuse and expected single fault component failures.

The standard types of product safety compliance tests required today for listing of most products are:

- Dielectric Strength
- Insulation Resistance
- Leakage Current
- Ground Continuity
- Ground Bond

Production Line Testing

Most manufacturers perform production line tests as a means of ensuring overall product quality. If, however, a product carries an approval mark of an independent testing laboratory, that laboratory usually requires mandatory production line testing to make sure that the product continues to meet its requirements over a long period of time.

In the US, test laboratories typically require production line tests for dielectric withstand (hipot) and ground continuity. European agencies usually require a ground bond test in addition to the dielectric withstand and ground continuity tests.

Approval agencies also require regular periodic calibration of the production line test equipment to make sure it meets their standards. They also conduct follow-up inspections on a regular schedule to verify construction of the product and the procedures used to test it. The manufacturer is normally required to keep calibration certificates and inspection documentation on file at all times.

Dielectric Strength

A dielectric strength test determines the suitability of the dielectric or insulation barrier between hazardous and non-hazardous parts. A dielectric barrier is commonly required by all established safety standards between hazardous circuits and user accessible circuits or surfaces. The dielectric strength test is a fundamental method of ensuring that a product is safe before it is placed on the market.



Figure 1: Typical AC/DC/IR Hipot Tester

The dielectric barrier protects the user from exposure to dangerous electrical potentials. The most common points of application for a dielectric withstand test are between AC primary circuits and low voltage secondary circuits, as well as between AC primary circuits and user-accessible conductive parts/ground.

Confirming that the proper dielectric barrier exists between these areas verifies the existence of a level of protection from electric shock hazards under normal and single fault condi-

tions. A dielectric withstand test (dielectric strength test) appears in nearly every product safety standard and is a fundamental test employed to check a fully assembled product as it exits the production line.

Insulation Resistance

Insulation resistance measurements are generally conducted to determine the actual resistance between the two points of test. This test is similar to a DC hipot test except that it displays resistance rather than leakage current. It serves as a practical and effective method of verifying suitability of the product for use by the public.



Figure 2: Typical Megohmmeter/IR Tester

Leakage Current Tests

All products that use an AC line source as power have some associated leakage current when the device is turned on and operating. This leakage current normally flows from the AC line source through the ground path in the product and back to earth ground through the ground blade on the power cord. On products without a ground blade or those in which the ground is malfunctioning, a potential can develop on metal surfaces of the product. If an individual then comes in contact with the exposed metal surface, this individual then becomes the ground path for the product.

Under this condition, a certain amount of leakage current flows through the person exposed to the metal surface. If the leakage current is extremely low, typically less than 0.5mA, the person should not notice he/she is in the path of the current flow. At levels higher than this, the person can experience a startle reaction or worse.

For this reason, products that do not use a ground on the power cord generally are limited to a maximum leakage current of 0.5mA or less. Products that exceed this level normally have a ground on the power cord to conduct the leakage current back to ground, thereby protecting a person who comes in contact with any exposed metal on the product. Limits on leakage current are significantly less on medical products.

The leakage current discussed here is different from the measurement of leakage current during a dielectric withstand or hipot test. During a dielectric withstand test, a high voltage generally greater than 1000V is applied between the hot and neutral lines and the ground of the DUT. The leakage current is then measured. In a leakage current test, the product is on and operating via standard line voltage, such as 120VAC. The leakage current is then measured using a special circuit that simulates the impedance of the human body.

Ground Continuity

A ground continuity test checks that a path exists between all exposed conductive metal surfaces and the power system ground. This ground circuit provides the most fundamental means of electrical shock protection for a user.

If a fault occurs in the product that causes power line voltage to be connected to a surface a user might touch, a high current will flow through the connection to the power system ground, causing a circuit breaker to trip or a fuse to blow, thus protecting the user from shock.

The ground continuity test is normally performed using a low current DC source (<1 Amp) to determine that there is a low resistance between the ground blade on the power cord and any exposed metal on the product.



Figure 3: Typical Hipot with Ground Continuity Tester

Ground Bond

A ground bond test verifies integrity of the ground path by applying a high current, low voltage source to the ground path circuit, typically a 25 or 30A current. This test is similar to the ground continuity test with the additional benefit of verifying how a product will perform under actual fault conditions. When a ground fault occurs, current starts to flow through the ground circuit. If the current-carrying capacity is high enough and the circuit resistance low enough, the system operates properly and the user is protected from shock.

If, however, the ground circuit cannot carry enough current or has too high an electrical resistance, the circuit breaker may not trip or the fuse may not blow. If this occurs, voltage can build up to a point where current will flow through the user's body instead of the ground circuit. A ground bond test measures the resistance of the ground circuit and verifies the adequacy of the connection.



Figure 4: Typical Ground Bond Tester

Product Safety Tests

Dielectric Strength Tests

A dielectric strength test, commonly called a "dielectric withstand", "high potential", or "hipot" test, is a stress test of the insulation of a device under test (DUT). Such a test applies a voltage to the DUT that is much higher than normal operating voltage, typically 1000V AC plus twice the normal operating voltage. For a household appliance designed to operate at 120 or 240V AC, the test voltage is therefore usually about 1250 to 1500V AC.

A DC hipot test can usually be substituted for an AC hipot test. The best voltage for a DC hipot is normally higher than the AC test voltage by a factor of 1.414. A product that would be tested at 1500V AC would be tested at 2121V DC.

For double-insulated products, the required test voltages may be much higher, such as 2500 VAC or even 4000 VAC for a 120 VAC power tool. The voltage is applied between the operating circuits and the chassis or ground - the parts of a product that a consumer might touch or otherwise come in contact with.

Refer to Figure 5 for typical AC hipot test setups. The setup for a DC hipot test would be identical.

The purpose of the test is to make sure that consumers do not receive an electrical shock when they use the product, which might be caused by a breakdown of the electrical insulation.

The test also detects possible defects in design and workmanship that cause components and conductors to be too closely spaced. The danger is that air gaps between conductors or circuit components may become clogged with dust, dirt, and other contaminants over time in typical user environments. If the design spacing is inadequate, a shock hazard can occur after a period of use. By subjecting the product to a very high voltage, the hipot test overstresses the product to the point that arcing may occur if

the spacing is too close. If the product passes the hipot test, it is very unlikely to cause an electrical shock in normal use.

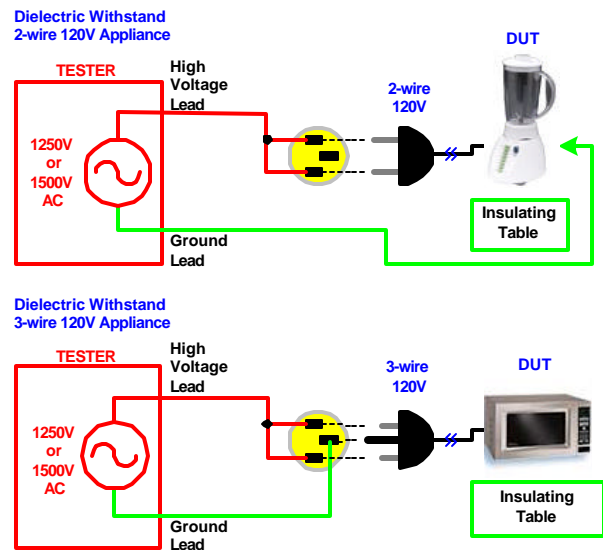

Figure 5: Typical AC Hipot Test

Withstanding a very high voltage means that a large margin of safety exists for the protection of the consumer. Regulatory agencies usually require a stringent hipot test as a product "type test" before releasing the product for sale to the public and another less demanding test to be used on the production line. As a rule, testing laboratories consider the hipot test to be the most important safeguard for the consumer. They may accept "design" or "type" tests for other types of tests, but they always require hipot tests for 100% of the units in a production line.

AC or DC

The voltage used in a hipot test can be either AC or DC, depending on the requirements established by the regulatory testing agency. There are advantages and disadvantages of both. The typical rule of thumb used to select an AC or DC test is if the DUT is powered by AC, then use an AC test; if it is powered by DC, use a DC test.

AC Hipot Tests

With an AC hipot test, a long ramp time is usually not required (except with certain sensitive devices). AC testing also has the advantages of checking both polarities of voltage and of not needing to discharge the DUT after testing is complete.

AC testing, however, does have some disadvantages. An AC test must consider the effects of both real and reactive current (see Glossary for definition of terms). When you apply an AC voltage, the current that flows is equal to the voltage divided by the impedance. The impedance, however, is complex because it contains both resistive (real) and capacitive (reactive) components.

Because these two components of AC current are out of phase with each other, they combine in a complex manner to form the total current, as shown in Figure 6. Since the magnitudes of the two components can be significantly different from each other, the leakage current (the "real" component) of a product with large amounts of capacitance can, with some testers, increase significantly without being detected by the test.

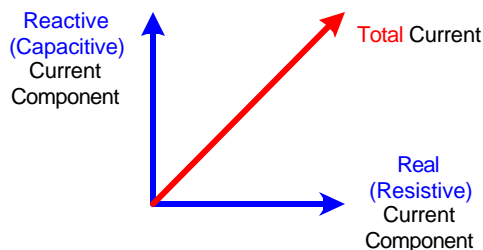

Figure 6: Real and Reactive Current

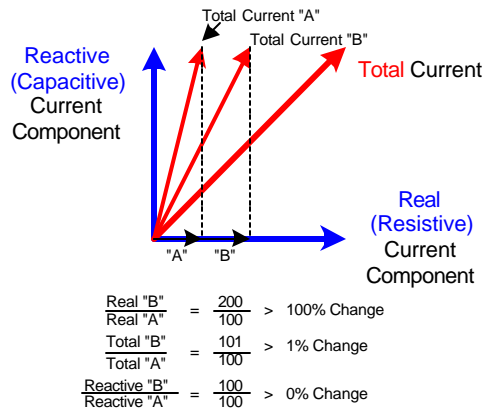

Figure 7: Masking Effect of High Capacitance

As shown in Figure 7, an increase of 100% in leakage current causes only a very small (1%) increase in total current when the total current has a high reactive component. The tester must therefore be very sensitive to detect a change in total current in a DUT with high capacitance.

AC testing at high voltage levels may also degrade some types of insulation. To avoid such problems, most manufacturers try not to exceed the required voltage levels and hold times, and to minimize the number of tests performed on a given product.

DC Hipot Tests

A typical DC hipot test applies a voltage in gradual steps, commonly called ramping, pausing after each increase to allow the capacitance of the DUT to absorb a charge and stabilize. As shown in Figure 8, the current increases sharply after each increase in voltage as the capacitance charges, and then decreases to a low steady-state value. The time required for the charging current to decay after each step is called the stabilization time. Current that flows after the stabilization time has passed represents the leakage current through the insulation.

If the voltage steps are too large, the sharp rise in charging current when the step is applied may exceed the high current limit, causing the test to fail prematurely. The magnitude and tim-

ing of the steps, therefore, should be carefully matched to the characteristics of the DUT.

By monitoring current flow as you gradually increase the applied voltage, waiting for the charging current to decay, and observing the leakage current (if any), you can detect a potential insulation breakdown before it occurs. If the leakage current suddenly starts to increase over the expected value, an insulation breakdown is likely to occur soon. Interrupting the test at this point can save the insulation from breakdown. The test fails but the product is not damaged and may be salvaged by visual inspection or some other means. Such a test, therefore, can be classed as "nondestructive". If the product being tested does not have significant capacitance, there is little or no charging current, and the rate at which the voltage is gradually increased can be much more rapid.

Because a DC hipot test charges the capacitance of a DUT, the charge itself can present a hazard to testing personnel that must be removed after the test is over. Remove the stored capacitance by discharging the DUT to ground. Typically, the hipot tester automatically discharges the DUT for the same period of time the test voltage was applied.

Arcing

No arcing or "sparking" should occur in an insulation stress test. If it does start to occur, the insulation is about to fail. A good tester, therefore, should detect presence of any arcing before real damage occurs.

An electrical arc is characterized by very rapid variations in voltage and current (Figure 9). It also produces an audible crackling or "zapping" sound. Because of these rapid changes, arcing can be detected - as soon as it starts to occur - by sensing for the presence of high frequency energy. This can be accomplished through the use of an electrical filter circuit in the tester.

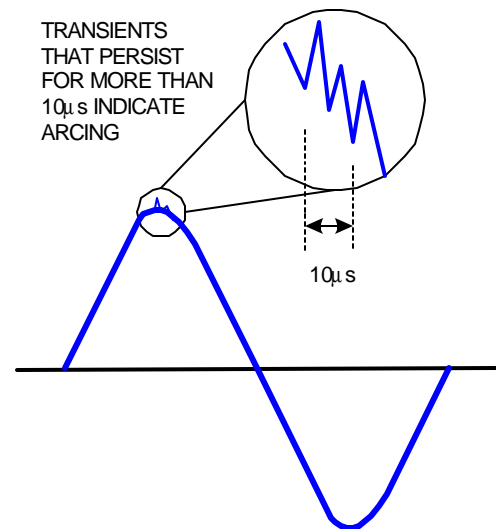

Figure 9: Voltage Wave during Arcing

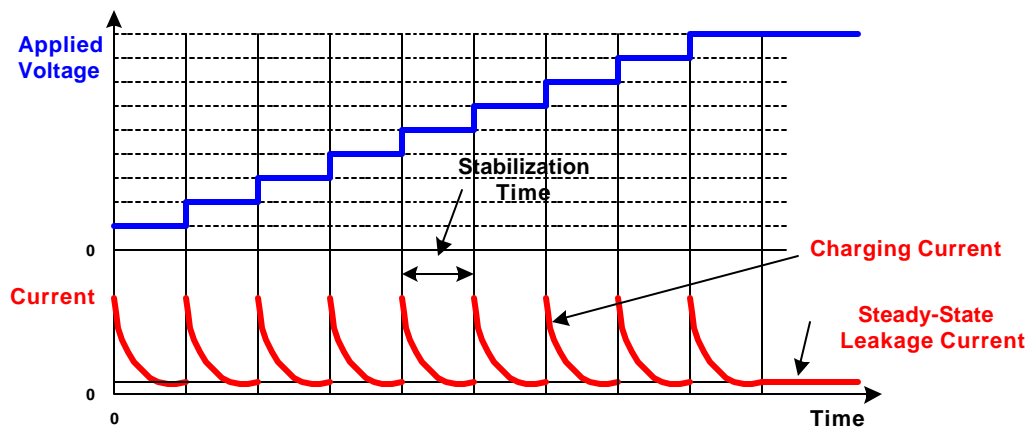

Figure 8: Charging Current

The circuit continuously monitors the current flowing through the DUT (which may be either AC or DC) and checks the magnitude and timing of deviations from normal values. If a high frequency component is found that persists for longer than a specified time, which may be as short as 10 microseconds, the circuit interprets this as an arc and immediately alarms and terminates the test. Arcs that last less than 10 microseconds are not considered harmful.

The arc detection level can usually be adjusted to prevent false arc failures caused by environmental influences such as electrical noise.

Arcing can be a valuable tool for evaluating the performance of insulation and dielectric barriers within a product. Currently there are no standards that require the use of arc detection in the determination of the safety of a product.

Line Regulation

Users should be aware of possible effects on tester performance of changes in line voltage and output load. The line voltage that powers a tester can typically vary by $\pm 5\%$. Since the tester usually incorporates a transformer of some kind to generate its high voltage output, a change in input voltage, unless corrected, can produce a corresponding change in output level (Figure 10). The problem arises if a drop in input voltage causes the output voltage to drop below the level required for the hipot test. If this situation occurs, the tester could pass a DUT

that really should have failed, compromising the integrity of the test.

Older analog testers that relied on amplifying the 60 Hz line voltage were extremely susceptible to changes in line voltage. Even small changes in line voltage could significantly affect output voltage.

To avoid the line regulation problem, most modern testers internally monitor the output voltage and automatically compensate for any fluctuations in line voltage, ensuring that the output voltage is always at the correct level.

Load Regulation

A similar problem can occur when a DUT draws current (load) from the tester (Figure 11). This small current, as it flows through the internal resistance of the tester, can cause a drop in the output voltage of the tester. The magnitude of the voltage drop is equal to the current times the internal resistance. If either (or both) of these values is too high, the output voltage of the tester may fall below the level required for a valid test. This problem is more severe in a production line environment where a given tester may be switched frequently from one type of DUT to another, which may have widely different characteristics.

Modern testers, therefore, compensate for load regulation by directly sensing the output voltage and automatically correcting for any variations.

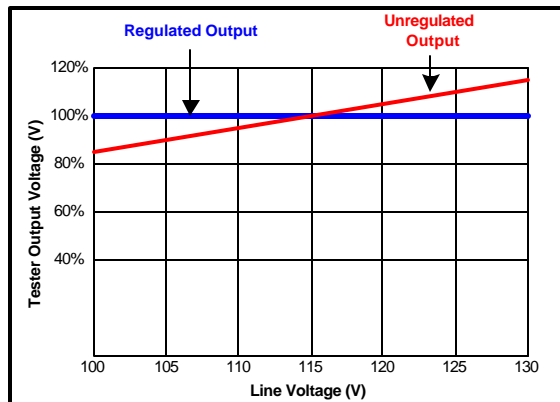

Figure 10: Line Regulation

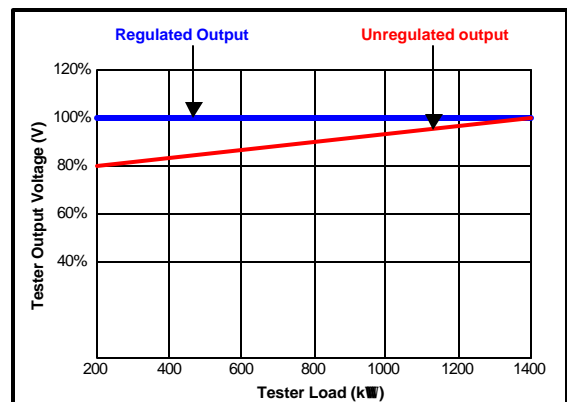

Figure 11: Load Regulation

Ramping

With AC hipot testing, high voltage is usually applied directly to the DUT without the gradual stepped increases used with DC hipot testing. This approach, however, can cause potential damage to some types of electrical circuit components. Because of this, some testers use electronic ramping to increase the voltage from zero to the test value smoothly over a period of time.

Agency test specifications require that a tester must produce a pure sine wave output voltage. In earlier systems, every adjustment to the tester that increased the output voltage could cause a distortion, such as a spike or high frequency transient, to appear in the voltage wave produced by the tester. The testers, therefore, did not fully comply with the agency requirements.

Modern testers, however, have eliminated this problem by electronically controlling the voltage and maintaining an undistorted waveform over the whole range as it is ramped from zero to the final value. This not only meets the agency requirements but also prevents spikes from damaging the DUT.

Min/Max Current Detection

or Setting Low/High Current Limits

Agency requirements specify a maximum current limit for a successful hipot test, but they do not specify any minimum level. Omission of such a requirement, however, means that under some conditions it is possible for a tester to pass defective DUTs.

Setting a maximum (high) current limit tells the hipot tester to shut down when that current level is reached. Any value above the high current limit is considered a Fail and any value below the set high limit is considered a Pass. Setting a minimum (low) current limit tells the hipot tester to shut down if there is not the specified minimum amount of current after the test is initiated.

Any value above the low current limit is considered a Pass and any value below the set low limit is considered a Fail. Refer to Figure 12.

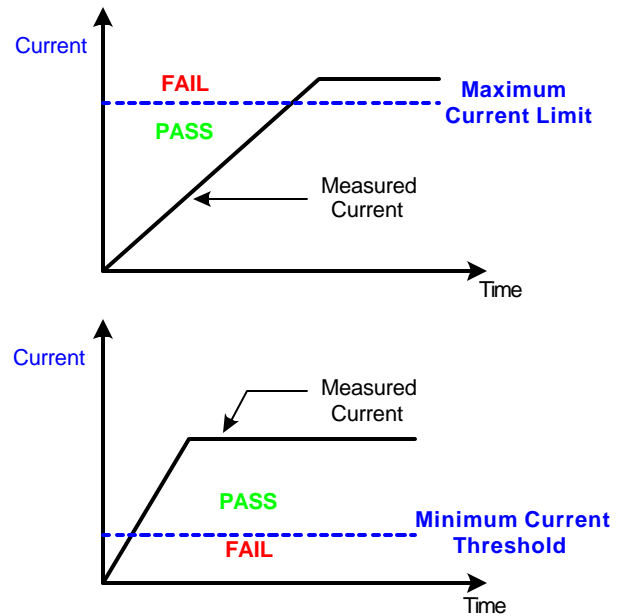

Figure 12: Min/Max Current Limits

In a properly functioning hipot test setup, a very small current safely flows through the DUT and the associated cables and fixtures. If, however, the circuit is broken because of a faulty fixture or cable connection, the integrity of the test is compromised. Unless the tester monitors for the minimum current, a break in the ground connection can cause the tester to indicate a successful test even though the DUT is defective because the tester is looking at an open circuit and may not even be connected to the DUT. The use of a low limit can also detect if the power switch is in its on position as required for proper testing. A tester that monitors current and sounds an alarm when it falls below a minimum level can detect a break in the test setup circuit and alert the operator immediately.

Ground Continuity Test

The purpose of a ground continuity test is to verify that all conductive parts of a product that are exposed to user contact are connected to the power line ground (the "green" wire). The theory is that if an insulation failure occurs that

**Figure 13:
Test Setup for Ground
Continuity**

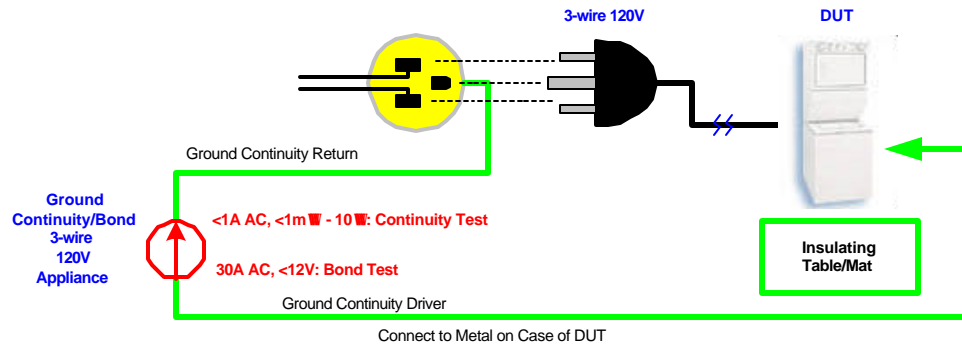

connects power line voltage to an exposed part and a user then comes into contact with that part, current will flow through the low resistance ground path to the green wire, tripping a circuit breaker or blowing a fuse, rather than flowing through the higher resistance of the user's body. Connecting all exposed conductive parts solidly to ground safely diverts the current away from the person.

Since many older homes may be wired as 2-wire systems without solid ground connections, regulatory agencies require all products manufactured with 3-wire cords to pass the same hipot tests as ungrounded products. In such cases, the user is protected by the electrical insulation rather than by the safety ground.

Ground continuity tests are normally performed with a low current DC signal that checks to ensure that the ground connection has a resistance of less than 1 ohm. Ground continuity testing is not only helpful in determining how well a product will fare during a laboratory investigation, but also is useful in a production line environment to ensure quality and user safety.

Polarization Test

A polarization test is usually performed as part of one of the other tests, such as a line voltage leakage or a hipot test. It is a simple test that verifies that a product supplied with a polarized line cord (either a 3-prong plug or a 2-prong plug with the neutral prong larger than the other) is properly connected.

The test may be just a visual inspection or it may be a wiring continuity check. A main purpose of such a test is to ensure that the line and neutral conductors are not interchanged.

Ground Bond Test

The purpose of a ground bond test is to protect the user of a product from hazards that could be caused by an inadequate or faulty ground connection. It differs from a ground continuity test in that it tests how much current the ground circuit can safely carry. Ground bond is a high current ac test that measures resistance of the ground path under high current conditions.

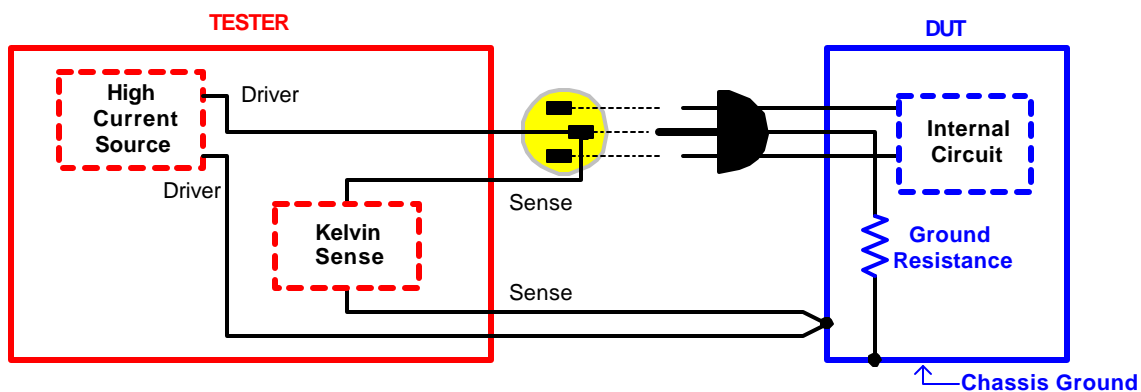

Figure 14: Ground Bond Test with a Kelvin Connection

For example, a product may pass a ground continuity test with a frayed wire containing only a few strands of wire. The circuit, however, would fail immediately if a high current ground fault should occur - causing an open ground connection.

This condition could present a hazard to the user, because part of the product might then have no ground protection at all. If a short occurred between line voltage and an exposed part where no ground exists, users could experience an electrical shock if they touched the part.

The ground bond test, therefore, should verify that the ground circuit has a very low resistance and a high current carrying capacity. This ensures that occurrence of a single ground fault on the product will cause the protective circuit breakers or fuses to shut off power to the device automatically.

Ground bond testing requires application of a high current source to a conductive surface of the product and measurement of the voltage drop across the ground connection to determine that bonding is adequate and that the circuit can carry the specified current safely.

One common method of ground bond testing, shown in Figure 14, applies a 25A source between the protective grounding terminal of the device and all conductive parts that are accessible to the user. The tester used for this purpose supplies the required current and displays the ground circuit resistance in ohms or milliohms.

Because the resistance to ground is usually a very low value, the resistance of the connecting leads from the tester itself can cause errors in the measurement. Such errors can be corrected either by measuring the resistance of the leads before the test and then subtracting that value from the test value or by using a so-called "Kelvin" test setup. A Kelvin connection automatically compensates for the lead resistance

by bringing an extra lead to the point of measurement. The extra lead is connected so as to balance out the resistance of the test lead. A typical test setup with a Kelvin connection is illustrated in Figure 14.

Most standards recommend a ground resistance of ≤ 100 milliohms, excluding the power cable.

Insulation Resistance Test

As the name implies, an insulation resistance test measures the total resistance between any two points separated by electrical insulation. The test, therefore, determines how effective the dielectric (insulation) is in resisting the flow of electrical current. Such tests are useful for checking the quality of insulation, not only when a product is first manufactured but also over time as the product is used. Performing such tests at regular time intervals can detect impending insulation failures before they occur and prevent user accidents or costly product repairs.

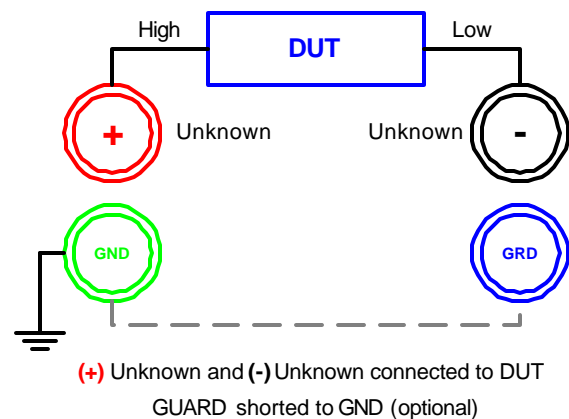

Figure 15: 2-Wire Ungrounded Connection

As shown in Figure 15, the 2-wire ungrounded connection is the recommended setup for testing ungrounded components. This is the most common configuration for testing 2-terminal devices such as capacitors, resistors, and other discrete components.

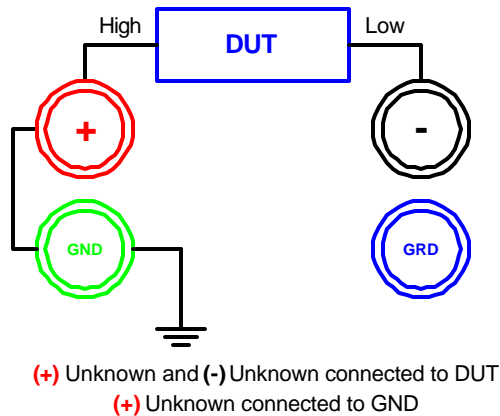

Figure 16: 2-Wire Grounded Connection

Referring to Figure 16, the 2-wire grounded measurement is the recommended connection for testing grounded components. A grounded component is one in which one of its connections goes to an earth ground, whereas an ungrounded component is one in which neither connection goes to earth ground. Measurement of insulation resistance of a cable in a water bath is a typical application of a 2-wire grounded connection.

Measurement Procedure

An insulation resistance test usually has four phases: charge, dwell, measure, and discharge. During the charge phase, the voltage is ramped from zero to the selected voltage, which provides stabilization time and limits the inrush current to the DUT. Once the voltage reaches the selected value, the voltage can then be allowed to dwell or hold at this voltage before measurements begin.

Once the resistance has been measured for the selected time, the DUT is discharged back to 0V during the final phase.

Insulation resistance testers typically have 4 output connections - ground, shield, (+), and (-) - to cover a wide variety of applications. The output voltage is typically in the range of 50 to 1000 Volts DC. In performing the test, the operator first connects the DUT as shown in Figures 15 or 16.

The instrument measures and displays the measured resistance. When the voltage is applied, some current immediately starts to flow through the insulation. This current flow has three components - a "dielectric absorption" current, a charging current, and a leakage current.

Dielectric Absorption

Dielectric absorption is a physical phenomenon in which the insulation appears to "absorb" and retain an electrical charge slowly over time. This is demonstrated by applying a voltage to a capacitor for an extended period of time then quickly discharging it to zero voltage. If the capacitor is left open circuited for a long period and is then connected to a voltmeter, the meter will read a small voltage. This residual voltage is caused by "dielectric absorption". This phenomenon is commonly associated with electrolytic capacitors.

When you measure IR of various plastic materials, this phenomenon causes the IR value to increase over time. The inflated IR value is caused by the material absorbing charge slowly over time. This absorbed charge looks like leakage.

Charging Current

Since any insulated product exhibits the basic characteristics of a capacitor, two conductors separated by a dielectric, application of a voltage across the insulation causes a current to flow as the capacitor charges. Depending on the capacitance of the product, this current instantaneously rises to a high value when the voltage is applied and then quickly decays exponentially to zero as the product becomes fully charged. Charging current decays to zero much more rapidly than the dielectric absorption current.

Leakage Current

The steady-state current that flows through the insulation is called the leakage current.

**Figure 17:
Test Setup
for Line
Voltage**

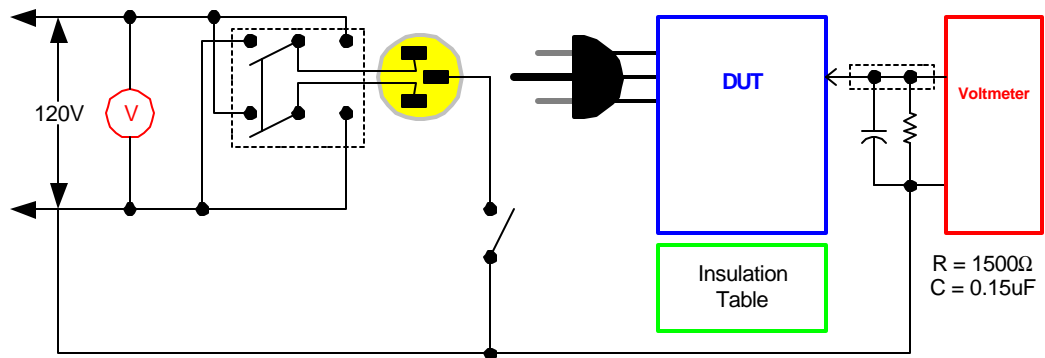

It is equal to the applied voltage divided by the insulation resistance. The purpose of the test is to measure insulation resistance. To calculate the IR value, apply the voltage, measure the steady-state leakage current (after the dielectric absorption and charging currents have decayed to zero) and then divide the voltage by the current. If the insulation resistance meets or exceeds the required value, the test is successful. If not, the test is failed.

Leakage Current Test

A line voltage leakage current test simulates the effect of a person touching exposed metal parts of a product and detects whether or not the leakage current that would flow through the person's body remains below a safe level.

A person typically perceives current flow through his body when it reaches or exceeds 1mA (one thousandth of an ampere). Current above the threshold can cause an uncontrolled muscular spasm or shock. An equivalent circuit of the human body consists of an input resistance of 1500 ohms shunted by a capacitance of 0.15 microfarads.

To provide a margin of safety for the consumer, regulatory agencies usually require that a product exhibit a line voltage leakage current of less than 0.5mA. With some products equipped with 3-prong plugs and warning stickers, the permissible leakage current may be as high as 0.75mA, but the typical limit is 0.5mA. Since hipot tests are usually required for 100% of the units in a production line, and since hipot tests are more stringent, line voltage leakage tests

are normally specified as design or type tests and not as production line tests. Line voltage leakage tests are typically required on all medical products as a production test.

Line voltage leakage test are conducted with a circuit similar to that shown in Figure 17, measuring the leakage current under various fault conditions such as "no ground" or with line and neutral connections reversed. Voltage is applied first with normal line and neutral connections, followed by a test with the connections reversed, and then with no ground.

The measurement of leakage current is a requirement for type testing of any mains powered product. A compliance laboratory or National Recognized Test Lab (NRTL) normally performs the type testing on a sample of products during the design phase. Once the type testing is complete generally no further leakage testing is required on a production basis with the exception of medical products. Leakage current measurements are routinely performed on the production line for medical products for safety reasons.

Class	Equipment Type	Maximum Leakage Current
II Ungrounded	All	0.25mA
I Grounded	Hand-held	0.75mA
I Grounded	Movable (Not hand-held)	3.5mA
I Grounded	Stationary, Type A	3.5mA

Table 4: Some UL Values for Leakage Current Limits

There are several different types of leakage current: Earth Line Leakage, Touch/Chassis (formerly Enclosure) Leakage, Patient Leakage, and Patient Auxiliary Current. The basic differences between leakage currents depend upon how a person might come in contact with the product or the measurement. For example the leakage that would flow through a persons body if they touched the outside enclosure of a product would be Touch/Chassis or Enclosure leakage.

What is a safe level of leakage?

Depending on the type of equipment, acceptable levels of leakage current have been determined and are generally outlined in the appropriate international or regional standard. Acceptable levels of leakage current are dependant on the classification of the particular type of equipment. The basic principle behind protection against electrical shock is to have at least two levels of protection.

Class I

Class I products use Basic Insulation in combination with Protective Earth. These products will have a three-prong power cord and the ground blade will be attached to any accessible metal on the product. Class I products have higher allowable leakage currents as the

ground provides a level of protection for the operator and effectively drains off leakage current that a person might come in contact with. Leakage current limits for Class I products also vary depending upon whether the power cord is detachable or permanent.

Class II

Products that have a two-prong power cord are Class II products. Class II products rely not only on basic insulation but also supplemental insulation or reinforced insulation. These products are often referred to as double insulated products as protection against shock relies on two layers of insulation. Since there is no protective earth to drain off excess leakage current the limits of acceptable leakage current for Class II products are lower than Class I products.

Measurement of Leakage Current

The measured leakage current values are then compared with acceptable limits based upon the type of product being tested (class), point of contact with the product (Earth, Touch, Patient) and operation of the product under normal and single fault conditions. Refer to Definitions in the Glossary.

Figure 18:
Class I Product

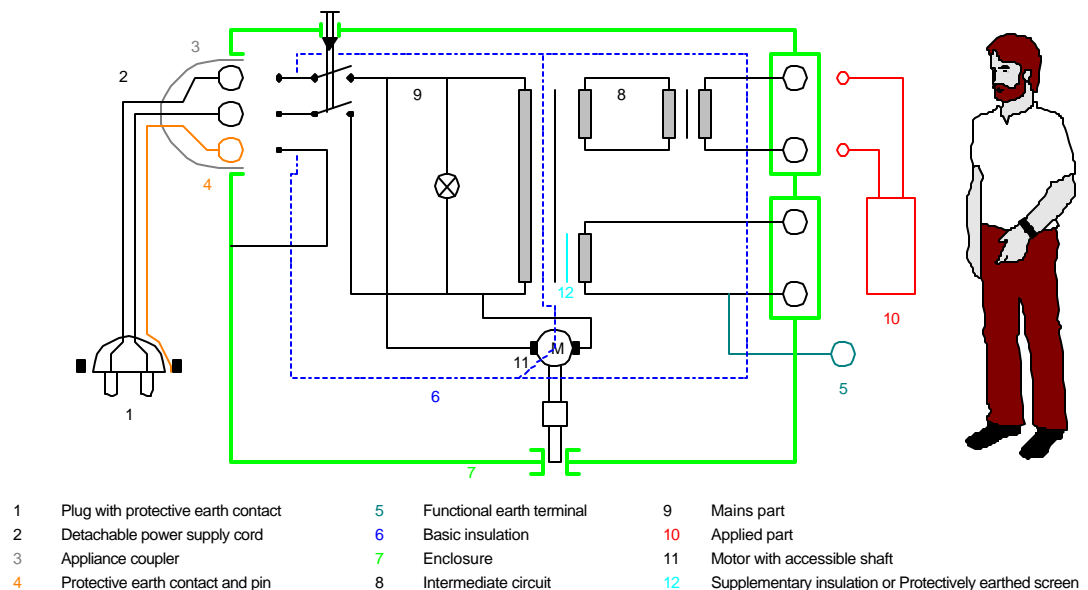

**Figure 19:
Class II Product**

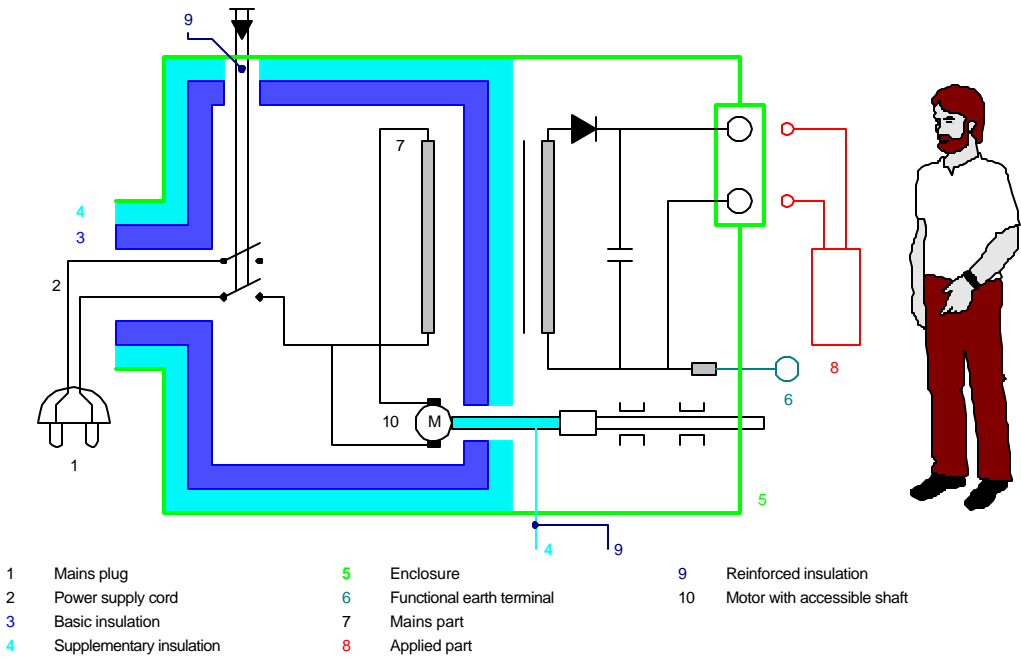

The leakage current measurements are performed with the product energized and in all conditions such as standby and full operation. The mains supply voltage is normally delivered via an isolation transformer to the product.

The mains supply voltage should be at 110% of the highest rated supply voltage and at the highest rated supply frequency. This means that a product rated for operation at 115VAC 60Hz and 230VAC 50Hz would be tested at 110% of 230VAC that equals 253VAC and at a line frequency of 60Hz.

The measuring instrument referred to as MD shall have an input impedance (Z) of $1M\Omega$ and a frequency characteristic that is flat from DC to 1MHz. Refer to Figure 20. The instrument shall indicate the true R.M.S. value of the voltage across the measuring impedance or the current flowing through the measuring device with an indicating error not exceeding $\pm 5\%$. The instrument shall also load the source of the leakage current with an impedance of approximately 1000Ω for frequencies from DC to 1MHz.

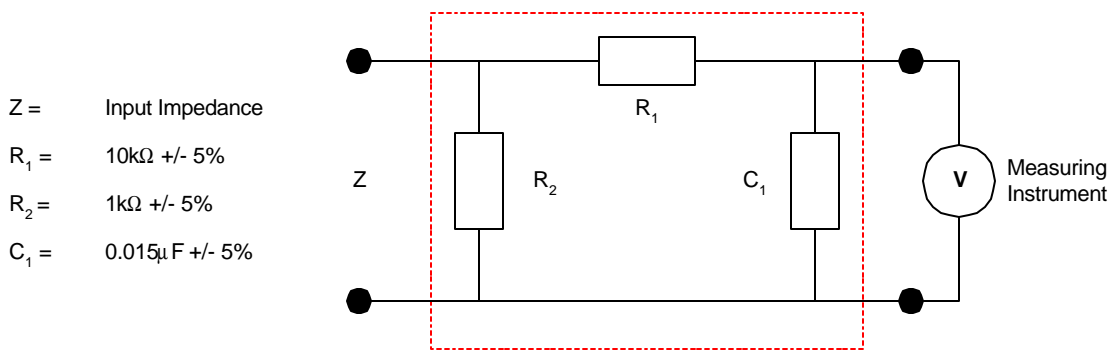

This figure is equivalent to  in IEC60601-1 Leakage Circuit Diagrams

Figure 20: Human Body Model or Network for IEC60601-1

This is accomplished by using a human body model or network attached to the input of the measuring instrument. Depending upon the standard being used the impedance of the human body model or network will change. Figure 20 shows a human body model or network used in IEC60601-1. There are a number of commercially available instruments that are specifically designed to perform leakage current measurements. These instruments have all of the correct accuracy, input impedance and typical selectable human body models for several popular standards built right in to the instrument.

Leakage currents are measured during both normal operation and fault conditions. Normal operation means the product energized in both standby and full operation. Medical devices also have the requirement for connection of any voltage or current permitted under normal operation to the signal input and output parts. Single fault conditions include opening of protective ground and opening of the neutral conductor on the mains supply. There can be additional fault conditions depending upon the design of the product.

There are some general rules that should be followed when performing a leakage current measurement. The product being tested should be placed on an insulating surface and significantly far away, 20cm, from any earthed metal surface. The measurement circuit and cables should be positioned as far away from unscreened power supply leads as possible and significantly far away from any earthed metal surface.

Refer to Application Notes 035117 & 035118 for additional information on Leakage Current Testing for Medical Products.

Operator Safety

Tester Environment

Determining the location of your test station is the first step in designing a safe and effective test station. The test station should be located away from traffic for the safety of anyone who may pass by the station and of course for the safety of the operator at the station. Limiting distractions to the test operator is an added step to ensure safety. The area should be marked with approved "**DANGER - HIGH VOLTAGE**" signs. The Hipot tester should have indicator lights to denote when high voltage is output. The test area should be separate from the assembly area.

There should be ample power supplied to the test station. Verify that the power wiring meets electrical code requirements for polarization and grounding. Always use an outlet that has a properly connected protection ground. Serious injury may result if the Hipot tester is not connected to earth ground. Before connecting the 3-prong power cord between the unit and the AC power source, make sure the voltage selection switches on the tester are in accordance with the power source being used. Arrange the power line connections so that, except for emergency lighting, all power is interrupted by a single, well marked, palm operated emergency switch located at the outside edge of the test area.

The test station should be constructed of non-conducting materials. An ESD mat is not a recommended platform for your test station, for it may cause erroneous readings. Metal objects should not be placed between operator and DUT. All other metal objects should be grounded. The test station should have sufficient space for the tester and DUT without the operator having to reach over the DUT to access the tester. The tester should be at least 3 inches away from the wall to provide proper airflow for the unit. Ideally the DUT should be isolated from the operator and tester. For larger DUT's, which are wheeled to the test station, the cart

should be non conductive with locking wheels. This is also true if the tester needs to be wheeled to the DUT. Keep the area clean and neat and arrange the equipment so that it is easy and safe for the operator to use.

There are many safety features, which can be added to your test station to prevent the operator from coming in contact with high voltage. **Guards** or enclosures can be placed around a DUT, they should be non-conducting and should be equipped with **safety interlocks** that interrupt all high voltages when open. Interlocks should be arranged so that operators are never exposed to high voltages under any conditions.

A **Ground Fault Interrupt (GFI)** circuit that monitors the high voltage output and return line is an excellent operator and instrument safety feature. The current exiting the instrument's high voltage output (I_{source}) is measured separately from the current flowing through the device under test (I_{device}). To stop the flow of this extraneous current, the GFI circuit is employed to detect a current imbalance (as small as 250uA) between the output and return, then shut down the high voltage immediately. QuadTech was the first company to manufacture a production hipot tester with a GFI circuit as standard.

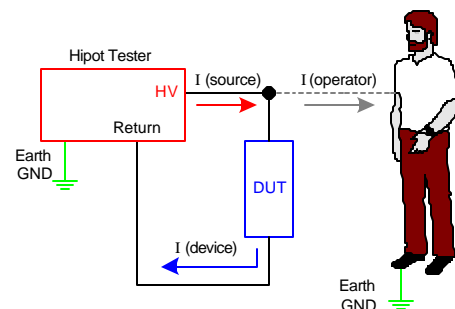
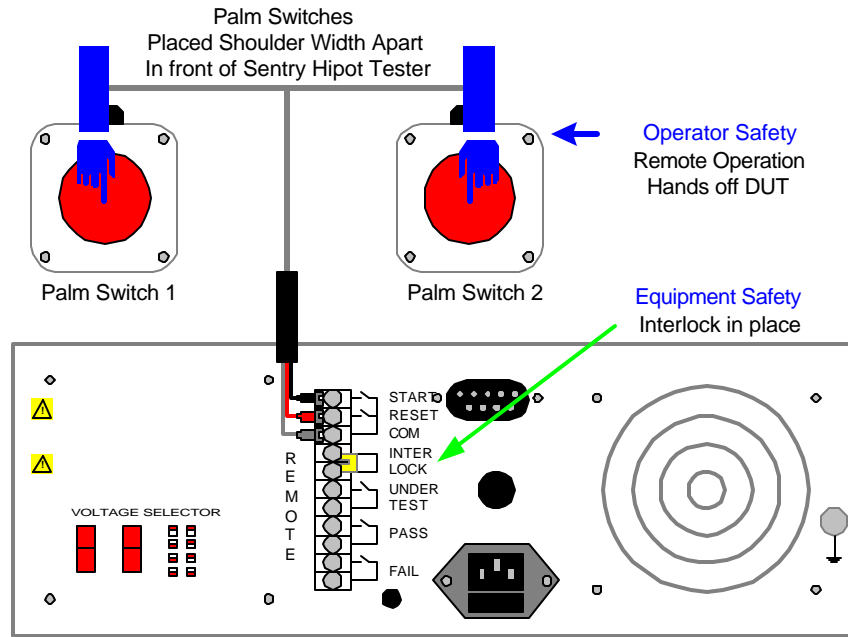

Figure 21: GFI Circuit

Palm switches are an easy to implement feature to prevent the operator from coming in contact with high voltage during testing. The basic operation of a palm switch requires the operator to use both hands to initiate a test and if one or both of the hands are removed from the

**Figure 22:
Palm Switches**



switch while testing, the test is immediately stopped. The switches are placed directly in front of the operator spaced shoulders width apart. Spacing the switches prevents an operator from trying to press both buttons down with one hand or object.

There is no high voltage applied to the output terminals and DUT until BOTH switches are pressed simultaneously. The operator cannot touch the DUT or test leads if both hands are on the palm switches. The switches are connected to the remote I/O on the Hipot tester, to the start, reset and common terminals. When the switches are in the down position the start is enabled, once one switch goes up the reset is enabled, terminating the output voltage of the Hipot. This method is safe, quick and effective. Refer to Figure 22.

More elaborate test stations may use the Hipot testers **Interlock** for added safety. **A light curtain** is one safety method that utilizes the interlock.

A light curtain is an infrared light beam that will open the interlock if anyone interrupts any part of the light beam. The output of the light curtain is connected the interlock terminal on the Hipot tester. If the interlock is open, high voltage is

immediately terminated. The light curtain is placed in between the Hipot tester or the DUT and the operator. In order for the operator to touch the high voltage they would have to pass through the light curtain, hence opening the interlock, which will terminate the high voltage. If the Hipot is placed behind the light curtain there must be a way to start the test.

A foot switch is an easy to implement method to start a test. Typical foot switches have two connectors. Connect one to the start terminal and the other to common, pressing the foot switch will initiate the Hipot test. Keep in mind you must ensure that nobody can reach the high voltage by going around the light curtain.

Define safety procedures to be used in emergency situations and train all personnel in how to use them. Most Hipot testers will automatically discharge your DUT. This is not necessarily the case if there is a power failure. A **"hot stick"** should be available to discharge the DUT in case of a power failure or if the device becomes disconnected during a test. This is necessary because unexpected, dangerous charges can build up during a test if a connection comes loose. Having **trained personnel** is the first step to a safe testing environment.

Operator Training

All operators should be given training in the basic theory of electrical circuits - voltage, current, resistance, AC vs. DC, Ohm's Law, and impedance.

They should also be taught the effects of electrical currents on the human body and how best to avoid shock hazards. The operator should be in good health, operators who are pregnant or have heart problems are not recommended candidates to work with High Voltage. Explain the workings and importance of safety interlocks and why they should never be disabled.

Explain the hazards of wearing metallic jewelry around electrical equipment and show how to interrupt power quickly in emergency situations.

Hold regular meetings to review and update safety procedures and regulations.

Program the necessary tests and store them in memory. Have a procedure available as to which memory location should be used for each device being tested. The procedure should also outline the test being performed (AC or DC, voltage, test time and limits). Use the key lock feature on your tester. This will avoid your programs being changed to unknown and unsafe values.

Explain the object of each test, show how it should be executed, and show how to handle every normal and abnormal situation that may occur. Make sure each operator understands how much he or she can handle alone and when supervisory personnel should be called in for help.

Consult with your local OSHA chapter for specific guidelines on incorporating the minimum performance requirements for the control of unexpected hazardous energy. This is specified in the OSHA 1910.147 regulation.

Testing Guidelines/Procedures

Some basic guidelines for performing electrical safety tests are outlined below.

1. Do not make any connections to a DUT unless you have verified that the High Voltage is OFF.
2. Never touch a DUT or its connections during a test.
3. When connecting leads to the DUT, always connect the Ground clip first.
4. Never touch the metal of a High Voltage probe directly. Only touch the insulated parts.
5. Use interlocked test fixtures only.
6. Verify all DUT connections before starting a test. Make sure that no other objects are near the DUT or the tester.
7. Keep the area neat and uncluttered and avoid crossing test leads.
8. Follow the prescribed procedure for each test exactly as written.
9. Verify all setup conditions before starting a test and examine all leads for signs of wear.
10. Verify the tester is functioning properly by use of a load box. This will also confirm the condition of the test leads.
11. Have a "hot stick" handy when performing a DC test and use it to discharge any connection or device that may become disconnected during a test. This is necessary because unexpected, dangerous charges can build up during a test if a connection comes loose.
12. At completion of a test turn OFF the High Voltage. If the test was DC, discharge the DUT for the prescribed time.

Test Equipment

Choosing the Right Tester

The first step in selecting test equipment is to define the types of tests to be performed on a given product. For a manufacturer, three items must be considered:

1. Tests required by the NRTL for approval and certification. (Includes type tests and production line tests.)
2. Optional tests needed by the manufacturer to ensure quality of the product and the manufacturing process.
3. Cost/benefit analysis of each optional test.

Since the NRTL specifies the tests they require for certification, the first item is easily defined. Refer to Appendix A for a list of tests required by various NRTLs for different classes of products.

The second item, however, is determined by manufacturing management for the purpose of process control and is largely dependent on the third item, cost/benefit analysis.

As described in preceding sections of this document, NRTLs usually require "type tests" for verifying basic safety of the product design and also "production tests" for ensuring that the approved product continues to meet the safety standards as long as it is sold to the general public.

Since the type tests are intended to verify safety of the "design" of a product, they are usually much more stringent than routine production tests performed on every unit as it emerges from the assembly line.

An AC dielectric withstand test is normally a required "type test" for any product. Most manufacturers also choose to perform all the other

basic tests as a matter of good design practice, even if they are not specifically required. Production line tests typically required by NRTLs are:

- Dielectric withstand - almost always required for all products.
- Ground bond - usually required for information technology products, medical equipment, audio/video products, laboratory, control, test & measurement products, household cooking products, and portable electric tools. Always recommended for products sold in Europe with the CE mark.
- Ground continuity - usually required for electric air heaters, household cooking and food serving appliances, vacuum and blower cleaners. Recommended by UL for products with 3-prong power cords.
- Insulation resistance - usually required for electric air heaters and electric motors.
- Line voltage leakage current - usually required for most medical products.
- Polarization - usually required for any product supplied with a 2-prong or 3-prong line cord.

Recommended Tester Features

In selecting a tester for "type testing", the major considerations are:

1. What tests are required? (AC hipot, DC hipot, IR, Ground Continuity, Ground Bond, Current Leakage)
2. What is the range of test voltage? What leakage current limits are required for the hipot test?
3. How should you connect the tester to the DUT?
4. Is there a requirement for connecting the tester to a PLC, computer, or other external device?
5. Are additional features desirable?

Such as:

- Programmable test setup
- Store and Recall of previous test setups
- Minimum current detection (plus maximum current detection)
- Ease of use in a production environment
- Operator convenience
- Displays and alarms
- Data communication Interface
- Front panel lockout
- Arc detection
- Sequence testing
- Automatic shutdown
- Wide range of Accessories
- Calibration service
- Competent service and support of the product

Feature descriptions are provided herein.

General Tester Features

Wide Range of Functions

A tester should be capable of performing all of the tests required for a particular product. This is usually much more economical than purchasing several single-function testers. If only a single test is required, of course, a simple, dedicated tester is all you need. Usually, however, a sequence of several tests is desired.

Wide Range of Test Voltage and Current

The tester should be capable of providing all voltages and currents needed for the range of tests to be performed.

For dielectric testing:	Voltage and Current
For ground bond:	Current and Resistance
For insulation resistance:	Voltage and Resistance

Wide Range of Insulation Levels

The tester should handle insulation resistance measurements in the ranges of $1M\Omega$ to $50G\Omega$ at commonly used voltages (from 50V to 1000V DC). For special situations a range as high as $2T\Omega$ may be needed.

Flexibility

The tester should be easily adaptable to different test requirements. Most modern testers provide this flexibility through programmability plus an ability to recall previously stored test setups on demand.

Line and Load Regulation

The tester should be designed so that normal variations in line voltage and connected load do not cause the output voltage and current measured at the DUT to rise above or fall below the levels required for the test. This improves test repeatability and greatly reduces inconsistencies in measurements.

Accuracy

To comply with agency requirements, tester accuracy should meet the following typical specifications:

AC High Voltage:	$\pm 1\%$ of reading +5V
DC High Voltage:	$\pm 1\%$ of reading +5V
Regulation:	$< 1\%$ +5V
Insulation Resistance:	$\pm 10\text{-}15\%$ of rdg +10 cts
Leakage Current:	$\pm 1.5\%$ + 5 cts
Breakdown:	$\pm 1\%$ of limit + 50mA
GC Output Current:	$\pm 1\%$ of setting +0.3A
GC Resistance:	$\pm 1\%$ of reading +3 cts

* GC = Ground Continuity

Easy to Use

The tester should have a well-designed front panel with easily read digital displays of measurements, settings, and pass/fail indicators. Audible alarms with acknowledgment are typically required by an NRTL. An ability to hold an alarm condition after operator acknowledgment can be useful for later analysis of the fault. All panel items should be clearly marked so that the function of each is readily apparent to anyone looking at the device for the first time.

The START TEST button should be large, well marked, and protected in a way that prevents accidental activation of a test. The STOP TEST button should also be easily identified (preferably bright red) and placed so as to be found quickly in an emergency.

Pushbuttons for setting, storing, or recalling test values, alarm limits, and test sequences should be clearly marked and easily operated by typical test personnel.

Operator Safety

The tester should be designed so that the test operator cannot be accidentally subjected to hazardous voltages such as those used for a hipot test, a line voltage leakage test, or an insulation resistance test.

Use of safety interlocks can provide this protection by automatically shutting down the high voltage output whenever a safety switch on the DUT is opened. In addition, the tester should be designed so that output current cannot exceed a value that would be harmful to a human (GFI circuit). Cables used for high voltage output and ground clips should be flexible, well insulated, and designed to be repeatedly plugged into and removed from the front panel over a long period of time without becoming frayed, worn, or ineffective.

Production Tester Features

Programmability

A modern production tester should be fully programmable, permitting a user to enter a complete sequence of test steps, test parameters, and pass/fail limits. This permits the tester to automatically execute a complete test or series of tests on a DUT.

Store/Recall of Test Programs

The ability to enter a test program and store it for later retrieval is a very useful feature. A user can then recall any of several stored test programs at any time, saving valuable setup and test time in both laboratory and production environments. This feature ensures that tests are always performed the same way.

Minimum Current Detection

The ability to detect minimum current in a hipot test guards against a false positive indication when the ground circuit is open. Without this feature, a fault in the ground circuit may be missed and cause an unsafe product to be released for shipment to customers.

Displays and Alarms

Most modern testers today use digital displays for indications of measurement values, test limits, and pass/fail results. An operator can more easily and accurately read a digital meter than an analog meter.

Data Communication Interface

Any production tester today must be equipped with some type of standard data communication interface for connection to remote data processing, computer, or control equipment. The typical interfaces are an IEEE-488 general-purpose interface bus and an RS232 serial communication line. The tester must also be capable of being remotely controlled by such equipment.

The advantage of an IEEE-488 interface is that it can transfer data at a high rate (typically 1 MB/sec). However, the length of the connection cannot exceed 20 meters. An RS232 serial line can be any length, but is limited to a low data transfer rate.

Front Panel Lockout

To prevent unauthorized operation or setup of the tester, a lockout feature (with password protection) is a desirable option. This feature ensures that changes to test limits or any tester functions are made only by a competent, authorized person.

Ramping

To avoid damage to components in a DUT, the high voltage output of the tester should be increased smoothly over the test range rather than as an abrupt step change. A quality tester should provide this feature without introducing spikes or distortion in the AC waveform. Modern testers also provide easily programmable ramp and hold times for each test step.

Automatic Range Sensing

The ability to automatically sense and select the correct range for an insulation resistance test is a very useful feature in an insulation tester. It saves time and ensures maximum accuracy of every measurement.

Automatic Shutdown on Alarm

When a DUT fails a test, the tester should automatically save the test result and interrupt the test immediately to avoid potential damage to the DUT.

Automatic Offset

In production environments, the ability to subtract leakage current due to test leads and test fixtures automatically from the instrument reading can be a great convenience. 4-Terminal Kelvin connections ensure maximum accuracy by preventing errors caused by measurement lead resistance. This feature is typically used to ensure accuracy of a ground bond test.

Arc Detection Before Breakdown

Arc detection is an anticipatory tool that can be used to detect an impending fault that may occur later in the product's life cycle. Modern testers provide this feature by detecting the presence of high frequency transients in the current waveform. If such variations exceed a specified level and persist for more than 10µsec, the tester should instantly alarm and interrupt the test.

Sequence Testing

Because a hipot test is a stress test of the insulation, it may in some cases cause degradation in the insulation resistance of a DUT. By measuring insulation resistance both before and after a hipot test, you can determine whether or not the hipot test damaged the insulation.

Therefore, the ability to program the tester to perform these tests automatically in sequence is of great benefit to a manufacturer.

Continuing Calibration Service

The supplier of safety test equipment should be able to offer calibration services on a continuing contract basis to make sure that the testers meet NRTL standards at all times. This is normally accomplished through a periodic on-site or off-site inspection and calibration of all covered equipment. The reference standards used by the supplier should be certified and traceable to NIST standards.

Wide Range of Accessories

A full complement of accessory items such as test probes or guns, high voltage lead sets in various lengths, corded product adapters, and foot switches are a real convenience. Having them readily available saves time and avoids the need for a test engineer to design or build such items himself.

Accessory Equipment

Some of the accessories typically needed for a lab or production test facility are:

- High Voltage Probes
- High Voltage Probe Guns (trigger operated)
- High Voltage Lead Sets with various lengths of cable
- Corded Product Adapter Fixture (to accept 2-prong or 3-prong line cords)
- Foot Switch to start/stop tests
- Ground Continuity Lead Set
- Power Entry Adapter Cable for Ground Continuity Tests
- Multiple Port Scanners for production test applications
- Rack Mount Kit

Tester Calibration

NIST Standards

The voltage, current, and impedance reference standards used by the equipment supplier for calibrating user test equipment should be certified traceable to NIST (National Institute of Standards and Technology) standards. This ensures sustained integrity of calibration accuracy.

120k Ω Leakage Impedance

UL specifies a 120k Ω resistance to check operation of a hipot tester. This requirement is based on a maximum current flow of 10mA when a voltage of 1250V is applied between the circuit of a DUT and ground. Using Ohm's Law, a voltage of 1250V divided by a current of 10mA gives a resistance of approximately 125k Ω .

To verify that a given hipot tester meets this standard for leakage impedance, the user sets the output voltage to the desired value and then connects a 120k Ω resistor across the output terminals. To be accepted, the tester must indicate a fault within 0.5 seconds. If it does not, the tester is not acceptable. The 120k Ω value is the minimum value at which the tester must indicate a fault. It is common for most equipment manufacturers to test their products with higher values of resistance, providing an extra margin of safety rather than testing right at the specified limit.

Refer to Application Note 035115 for additional information on resistive load boxes.

Tester Applications

Appliance Testing

In testing a typical 120/240V AC appliance, the test voltage should be applied between line and neutral (tied together) and the chassis ground (exposed metal parts). A corded product adapter fixture containing a receptacle with line and neutral terminals connected together is a convenient accessory for such tests. The fixture also provides a convenient ground connection for ground continuity tests.

If the appliance is double insulated, wrap the product in foil and use the foil as the ground reference. To test hard-wired appliances such as electric ranges with both 120 and 240 circuits, it is necessary to break any ground return connections between the two voltages before starting the test.

Since the object of the test is to test the insulation only, the test voltage should always be applied between ground and all operating circuits tied together (with all power switches closed; i.e., with the power switch ON) and never between line and neutral circuits.

Motor Testing

Since motors operate at elevated temperatures, the industry has adopted a standard of 40°C as the reference temperature for insulation resistance measurements. Therefore, if you run tests at any other temperature, you must apply a correction factor to the results. A typical chart for determining the correction factor is shown in Figure 24. To find the correction factor, draw a vertical line from the actual winding temperature up to the characteristic curve.

At the point where it crosses, read the value of the correction factor. Multiply the measured value by this factor to obtain the correct value at 40°C.

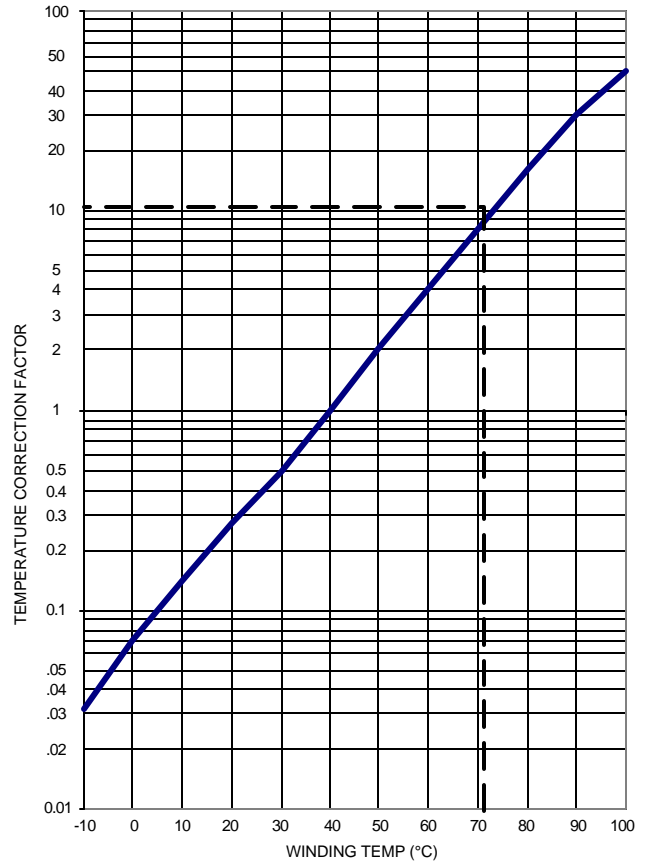
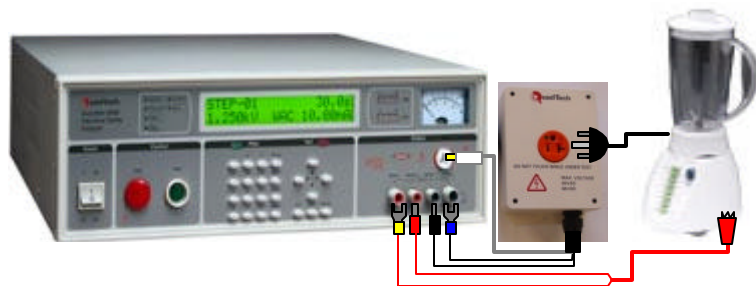

Figure 24: Temperature Correction Factor

A "polarization index" is sometimes used to evaluate large motors being tested for the first time. This index, which takes into account several time dependent characteristics such as dielectric absorption, is calculated by dividing a 10-minute IR measurement by a similar 1-minute IR reading.

Figure 23:
Tester Connected to an
Appliance through a Corded
Product Adapter



Insulation resistance measurements are also very valuable for checking motors that have been installed and operating for some time. By taking periodic measurements of insulation resistance over a long period of time, any degradation in insulation can be detected before real damage occurs.

Such tests are also valuable for motors subjected to flooding or very high humidity. After the winding has been baked dry, an IR test can verify its readiness to be placed back into service.

Transformer Testing

There are a number of tests that can be performed on transformers and coils such as inductance, mutual inductance, DC resistance, turns ratio and electrical safety tests including dielectric strength and leakage current. This article will deal primarily with electrical safety and the standards covering transformer testing.

In designing a product, it is important to select a transformer that has been tested in accordance with an appropriate standard for the intended use of that transformer. From a manufacturer's standpoint, the appropriate standard depends upon the industry to which the transformer will be marketed and the intended use of the transformer.

As an example, a transformer designed for the medical industry has lower leakage current and higher dielectric strength requirements than a general-purpose power transformer. Similarly, the requirements for an isolation transformer are completely different from those of a power transformer.

There are a wide variety of standards that cover transformer testing. Some of the more common standards for transformer design and testing are listed below. Components such as transformers that meet the requirements set forth in standards are generally referred to as "recognized" components in the USA and "certified" components in Canada.

A Recognized/Certified Component Directory (RCD) is available which contains such components. Regardless of the standard, the requirements for electrical safety testing are similar and include hipot and leakage current tests.

UL506 Specialty Transformers

This standard covers the vast majority of power transformers that are rated at less than 10kVA.

UL1411 Transformers and Motor Transformers for use in Audio-, Radio- and Television-Type Appliances

Most specifications are similar to UL506 with additional requirements for specific flame retardant material used in the manufacture of the transformer.

UL1876 Transformers for use in Electronic Equipment, Isolating Signal and Feedback

CSA C22.2, No. 66-1988 Specialty Transformers

This standard is similar to UL506 with some differences.

CSA C22.2, No. 223 Power Supplies with Extra-Low-Voltage Class 2 Outputs

The hipot test or dielectric withstand test is designed to check that the transformer can withstand a high potential between primary and secondary windings, primary and ground, and secondary and ground (see Figure 25). It should be noted that the windings should never be left open during hipot testing and the core should normally be connected to the low side of the tester.

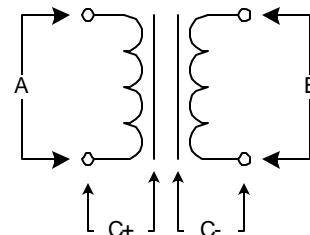

Figure 25: Transformer Test Setup

If the ratings between winding and core are different from one winding to another, connect the high side of the tester to the winding with the higher rating and the other to the low side.

The hipot voltage that the transformer can withstand is based upon the creepage distance between the two measurement points and the insulating material being used.

The hipot test voltages are outlined in the individual standards. Typical requirements for dielectric withstand on power transformers rated for 250V or less can be as low as 1500V for UL544 and as high as 4000V for EN60601. Transformers designed for medical applications are generally tested at higher voltages. It is also important to note that the hipot test is often performed after the transformer has been subjected to an abnormal or fault condition.

The leakage current is also checked between the primary and secondary/core. This test is designed to determine how much current could flow from the ground side of the secondary and core back through a human body. The amount of leakage current that can flow is based primarily upon the amount of capacitance between primary and secondary, and primary and core. In this test, the transformer is connected to the line voltage that is rated at 120VAC. The leakage current is then measured from the secondary and core back to ground. The lower the leakage current, the better the transformer. Limits for leakage current vary depending upon the standard. However, <100mA is typical and <10mA is achievable.

In summary, testing of transformers, especially those with multiple windings, can be complex. In selecting the test voltage to be applied, the appropriate standard, how the transformer will be used, and the voltage rating must be considered. Each relationship, primary-to-secondary, primary-to-core and secondary-to-core, etc., must be checked.

A leakage current test determines how much current could be available to an operator under a fault condition such as loss of ground.

Because of the number of test connections required, a hipot tester with a matrix scanner can be useful in automating the testing procedure. The use of a matrix scanner allows the windings to be connected together and the voltage to be applied between various points on the transformer without the intervention of an operator. Figure 26 shows a typical hipot tester with a matrix scanner. Additional measurements such as a DC resistance check of the windings can also be incorporated when a milliohm meter is also connected into the system.

Electrical Component Testing

In testing electrical components, clearly identify the points between which the insulation should be tested. Apply the test voltage only between those points and not between points that should be not stressed. Connect all those points together before making the test. You should also consider the effects of transients, step changes, and charging currents when designing tests of electrical components. In many cases, ramping is required to minimize such effects.

Figure 26:
Instrument for Testing a Transformer Product



Examples of High Performance Testers

Examples of various types of high quality testers manufactured by QuadTech, Inc. of Maynard, Massachusetts are provided herein.

Sentry Series Testers

In all models, this family of testers offers output voltage regulation, automatic offset, safety interlock, store/recall of 40 2-step (or 80 1-step) tests, front panel lockout, minimum current monitoring to 10 μ A, adjustable ramp and hold times, adjustable min/max current trip limits, arc detection, remote control, and a full compliment of accessories. The difference between models is provided in this section.



Figure 27: Sentry 35 AC/DC/IR Tester

Sentry 10 AC Hipot Tester

The Sentry 10 provides a programmable AC output voltage in 10V steps from 100V to 5000V (50/60 Hz frequency) and limits leakage current to 15mA.

Sentry 20 AC/DC Hipot Tester

The Sentry 20 is same as the Sentry 10 except it also has a programmable DC test voltage from 100V to 6000V in 10V steps and limits leakage current to 7.5mA.

Sentry 30 AC/DC/IR Hipot Tester

The Sentry 30 is the same as Sentry 20 with the addition of insulation resistance tests (10M Ω to 10G Ω) and a programmable test voltage from 50V DC to 1000V DC in 1V steps.

Sentry 15 AC Hipot Tester (CE Marked)

The Sentry 15 provides a programmable AC output voltage in 10V steps from 100V to 5000V (50/60 Hz frequency) and limits leakage current to 15mA.

Sentry 25 AC/DC Hipot Tester (CE)

The Sentry 25 is same as the Sentry 15 except it also has a programmable DC test voltage from 100V to 6000V in 10V steps and limits leakage current to 5mA.

Sentry 35 AC/DC/IR Hipot Tester (CE)

The Sentry 35 is the same as Sentry 25 with the addition of insulation resistance tests (10M Ω to 10G Ω) and a programmable test voltage from 50V DC to 1000V DC in 1V steps.

Sentry 50 Ground Bond Tester

The Sentry 50 provides high current testing of ground continuity between chassis and power cord ground. Output current range is programmable in 0.01 Amp steps from 1 to 30 Amps with a measurement range from 0.1 to 510 milliohms.



Figure 28: Sentry 50 Ground Bond Tester



Figure 29: Sentry 35, 50 and Corded Product Adapter

Guardian Series Testers

The Guardian Series Testers form a family of high performance combinational testers ideally suited for production environments where remote control (via IEEE-488 and RS232 ports) and automatic data processing are needed. Common features and differences between models are summarized herein.

Common Features

- AC & DC Dielectric Tests
- Wide Range of Programmable Voltages
- Programmable Trip Limits for Current
- Storage of V and I at breakdown
- Programmable Arc detection
- Programmable Ramp Times
- Auto HV Shutdown on Breakdown
- Minimum Current Detection
- Storage of Test Setups
- Auto Sequence Testing (IR/Hipot/IR)
- Programmable Leakage Current Detection
- Data Communication Interfaces (RS232 or IEEE 488)
- Easy to Use - LCD Displays, Menu Driven, Offline Test Setup
- Full Range of Accessory Options

Guardian 1000 Series

Guardian 1010 AC Hipot Tester

- AC High Voltage Output: 50V - 5kV AC, 1V/step, programmable, 50/60Hz
- Total and Real Current Measurement Range: 0.001mA - 30mA AC
- Ground Fault Interruption for Safety
- Ground Continuity Measurement with high and low limits



Figure 30: Guardian 1030S AC/DC/IR/SC Tester

Guardian 1030 AC/DC/IR Hipot Tester

- Same as 1010 plus:
- DC Output Voltage: 50V - 6kV DC, 1V/step, programmable, 0.1uA - 10mA DC current range
- Resistance Range: 0.1M Ω to 50G Ω , 1.5% Basic Accuracy

Guardian 1030S AC/DC/IR/SC Hipot Tester

- Same as 1030 plus:
- 8 HV Scan Channels

Guardian 2000 Series

Guardian 2510 AC Hipot Tester

- AC High Voltage Output: 0.1 - 5kV AC, 2V/step, programmable, 50/60Hz
- Real, Total and Imaginary Current Measurement
- Ground Fault Interruption for Safety
- Ground Continuity Measurement with high limit setting
- Front and Rear Connectors
- Continue Step on Fail, Stop Test on Pass, Continuous Voltage on Fail, Step & Increment

Guardian 2520 AC/DC Hipot Tester

- Same as 2510 plus:
- DC Output Voltage: 0.1 - 6kV DC, 2V/step, programmable, 0.1uA minimum leakage current

Guardian 2530 AC/DC/IR Hipot Tester

- Same as 2520 plus:
- Insulation Resistance: Voltage 50-1000VDC, 1V/step,
- Resistance Range: 10k Ω to 2T Ω , 2% Basic Accuracy



Figure 31: Guardian 2530 AC/DC/IR Hipot Tester

Guardian 6000 Series

Guardian 6000 Electrical Safety Analyzer

- AC High Voltage Output: 50V - 5kV AC, 10V/step, programmable ramp/hold, 50/60Hz, Leakage Current to 40mA AC, Adjustable arc detection
- DC Output Voltage: 50V - 6kV DC, 10V/step, leakage current to 20mA DC, Adjustable arc detection, Programmable ramp/hold times
- Insulation Resistance: 100k Ω - 50G Ω at 50 - 1000V adjustable high/low resistance
- Ground Bond: 1.0 to 30A 50/60 Hz AC, Programmable max voltage 5-15 V in 1V/step, Offset function, Measurement range: 0 - 500 milliohm
- Simulated Line Leakage Current: Voltage Range: 50 to 400V AC, 50/60Hz, Leakage current range: 0.01mA-10mA, Measurement circuit (IEC 950, UL1950, UL3101)



Figure 32: Guardian 6000 Electrical Safety Analyzer

Guardian 6100 Production Safety Analyzer for Electronic Medical Devices

G6000 with G6000-05 Scanner Factory Installed

- AC High Voltage Output: 50V - 5kV AC, Programmable ramp/hold, 50/60Hz, Leakage current to 40mA AC, Adjustable arc detection
- DC Output Voltage: 50V - 6kV DC, 10V/step, Leakage current to 20mA DC, Adjustable arc detection, Programmable ramp/hold times
- Insulation Resistance: 100k Ω - 50G Ω at 50 - 1000V adjustable high/low resistance
- Ground Bond: 1.0 to 30A 50/60 Hz AC, Programmable max voltage of 5-15 V, 1V/step, Offset function, Range: 0 - 500 milliohm
- Leakage Current: Voltage: 0 -300V AC, Current range: 0.1uA to 10mA, Measurement circuit: UL544NP, UL544P, UL1563, UL2601-1, IEC60601-1, IEC 950, UL1950 and UL3101 standards
Measurement mode: Normal, Reverse, Single Fault with Ground On/Off, Patient Auxilliary, Patient Leakage - Applied Part to Earth

Guardian 6200 Production Safety Analyzer For Single Phase Electrical Products

G6000 with G6000-04 Scanner Factory Installed

- AC High Voltage Output: 50V - 5kV AC, Programmable ramp/hold, 50/60Hz, Leakage current to 40mA AC, Adjustable arc detection
- DC Output Voltage: 50V - 6kV DC, Leakage current to 20mA DC, Adjustable arc detection,
- Insulation Resistance: 100k Ω - 50G Ω at 50 - 1000V, adjustable high/low resistance
- Ground Bond: 1.0 to 30A 50/60 Hz AC, Programmable max voltage of 5-15 V, 1V/step, Offset function, Range: 0 - 500 milliohm
- Line Leakage Current: Voltage: 0 - 300V AC, Current range: 0.1uA to 10mA, Measurement circuit: UL544NP, UL544P, UL1563, UL2601-1, IEC60601-1, IEC 950, UL1950 and UL3101standards
Measure mode: Normal, Reverse, Single Fault

Guardian Specialty Series

Guardian 500VA AC/DC/IR Hipot Tester

- AC High Voltage Output: 50V - 5kV AC, Programmable ramp/test, 50/60Hz, Leakage current to 100mA AC, Adjustable arc detection
- DC Output Voltage: 50V - 6kV DC, 1V/step, Leakage current to 20mA DC, Programmable ramp/test times
- Insulation Resistance: 100k - 50G Ω at 50 - 1000V, adjustable high/low resistance



Figure 33: Guardian 500VA Hipot Tester

Guardian 10kV AC Hipot Tester

- AC High Voltage Output: 100V - 10kV AC, Programmable ramp/test, 50/60Hz, Leakage current to 20mA AC, Adjustable arc detection

Guardian 12kV DC/IR Hipot Tester

- DC Output Voltage: 100V - 12kV DC, Leakage current to 10mA DC, Adjustable arc detection, Programmable ramp/test times
- Insulation Resistance: 100k Ω - 50G Ω at 100 - 1000V adjustable high/low resistance

Dedicated Function Test Instruments

In addition to Electrical Safety Testing (EST) equipment, QuadTech also manufactures milliohmmeters, megohmmeters and a complete line of LCR meters for test and analysis of passive components. Product specifications can be viewed at <http://www.quadtech.com>.

- Digibridge® Component Testers
- Precision LCR Meters
- Milliohmmeters
- Megohmmeters

Milliohmmeters:



Figure 34: 1880 Milliohmmeter

Megohmmeters:



Figure 35: 1864 Megohmmeter



Figure 36: 1867 Megohmmeter



Figure 37: 1865 Megohmmeter/IR Tester

Digibridges:



Figure 38: 1689 Digibridge



Figure 39: 1730 Digibridge

Precision LCR Meters:



Figure 40: 1920 Precision LCR Meter



Figure 41: 7600 Precision LCR Meter

Appendix A

Nationally Recognized Testing Laboratories (NRTL's) and Standards Organizations*

- Underwriters Laboratories, Inc.
333 Pfingsten Road Northbrook, Illinois 60062 USA
Tel: 847-272-8800, <http://www.ul.com>
- American National Standards Institute
1 West 42nd Street New York, NY 10036
Tel: 212-642-4900, FAX: 212-398-0023 <http://www.ansi.org>
- British Standards Institution
389 Chiswick High Road London W4 4AL United Kingdom
<http://www.bsi.org.uk>
- CENELEC Comité Européen de Normalisation Electrotechnique
Rue de Stassart, 35 B - 1050 BRUSSELS
Tel: + 32 2 519 68 71, FAX: + 32 2 519 69 19, <http://www.cenelec.be>
- Canadian Standards Association
Central Office 178 Rexdale Boulevard Etobicoke (Toronto), Ontario M9W 1R3
Tel: 416-747-4000 or 1-800-463-6727, <http://www.csa.ca>
- VDE-Verband Deutscher Elektrotechniker
Merlinstrasse 28 D-63069 Offenbach Federal
Republic of Germany
<http://www.vde.de>
- Japanese Standards Association
1-24, Akasaka 4, Minato-ku Tokyo 107 Japan
- IEC International Electrotechnical Commission
3, rue de Varembé o PO Box 131 1211 Geneva 20 o Switzerland
Tel: +41 22 919 02 11 FAX: +41 22 919 03 00, <http://www.iec.ch>
- The Institute of Electrical and Electronic Engineers, Inc
345 East 47th Street New York, New York 10017
Tel: 800-678-IEEE <http://www.ieee.org>
- NIST National Institute of Standards and Technology Calibration Program
Bldg. 820, Room 232, Gaithersburg, MD 20899
Tel: 301-75-2002, FAX: 301-869-3548, <http://www.nist.gov>
- National Electric Manufacturers Association Standards Publication Office
2101 L. Street, N.W. Suite 300 Washington, D.C. 20037 USA
Tel: 202-457-8400 FAX: 202-457-8473, <http://www.nema.org>
- ISO International Standards Organization
1, rue de Varembé Case postale 56 CH-1211 Genève 20 Switzerland
Tel: + 41 22 749 01 11, FAX: + 41 22 733 34 30, <http://www.iso.ch>
- OSHA Region 1 Regional Office
JFK Federal Building, Room E340 Boston, Massachusetts 02203
Tel: 617-565-9860, FAX: 617-565-9827, <http://www.osha.gov>
- TÜV Rheinland of North America, Inc.
12 Commerce Road Newton, CT 06470
Tel: 203-426-0888 <http://www.us.tuv.com>

* Partial Listing

Product Safety Standards*

Canada - Canadian Standards Association

CSA C22.2 No. 0-M91 (R2001) General Requirements, Canadian Electrical Code Part II.
CSA C22.2 No. 0.4-M1982 (R1999) Bonding & Grounding of Electrical Equipment
CSA C22.2 No. 14-95 (R2001) Industrial Control Equipment
CAN/CSA-C22.2 No. 71.1-M89 (R1999) Portable Electric Tools
CSA C22.2 No. 100-95 (R2000) Motors and Generators
CSA C22.2 No. 125-M1984 (R1999) CSA Electromedical Equipment
CSA C22.2 No. 151-M1986 (R1999) Laboratory Equipment
CSA C22.2 No. 205-M1983 (R1999) Signal Equipment
CSA C22.2 No. 601.1-M90 (R2001) Medical Electrical Equipment Part 1: General Requirements for Safety
CAN/CSA C22.2 No. 60950-00 Safety of Information Technology Equipment Including Electrical Business Equipment
CSA C22.2 No. 1010.1-92 (R1999) Safety Requirements for Electrical Equipment for Measurement, Control, and Laboratory Use. PART 1: General Requirements.

EEC European Economic Community

73/23 (1973) Low Voltage Directive with Amendments
84/539/EEC (1984) Directive on the Safety of Electro-Medical Equipment
85/349/EEC (1985) Directive Amending Directive 74/65/EEC on the Tax Relief's to be allowed on the Incorporation of Goods in Small Consignments of a Non-Commercial Character.
89/392/EEC (1989) Directive on the Application of the Laws of the Member States Relating to Machinery
93/465/EEC (1993) The Modules for the Various Phases of the Conformity Assessment Procedures and the Rules for the Affixing and Use of the CE Conformity Marking.
93/68/EEC (1993) CE Marking Directive Amending Directives: 73/23/EEC, 87/404/EEC, 88/37/EEC, 89/106/EEC, 89/EEC, 89/392/EEC, 89/686/EEC, 90/384/EEC, 90/385/EEC, 90/396/EEC, 91/263/EEC, 92/42/EEC.

IEC International Electrotechnical Commission

IEC 950 (1991) Safety of Information Technology Equipment Including Electrical Business Equipment
IEC 950 AMEND 1 (1992) First Amendment to IEC 950
IEC 950 AMEND 1 (1992) Second Amendment to IEC 950
IEC 950 AMEND 1 (1992) Third Amendment to IEC 950
IEC 60216-3 (2002-02) Ed 1.0 Electrical Insulating Materials
IEC 60512 (2002-02) ED 1.0 Connectors for Electronic Equipment
IEC 60335 (2002-02) ED 1.0 Household and Similar Electrical Appliances

* Partial Listing

Product Safety Standards*

USA

- ANSI Z535.4 (1987) Product Safety Signs and Labels (DRAFT)
- ANSI HF 100-1988 (1988) Human Factors Engineering of VDTs
- UL 94 (1996) Fifth Edition Test for Flammability of Plastic Materials for Parts in Devices & Appliances
- UL 746C (2001) Fifth Edition Polymeric Materials Use in Electrical Equipment Evaluations
- UL 817 (2001) Eleventh Edition Cord Sets and Power-Supply Cords
- UL 1004A (2001) First Edition Fire Pump Motors
- UL 1012 (1994) Sixth Edition Power Units Other Than Class 2
- UL 1018 (2001) Fifth Edition Electric Aquarium Equipment
- UL 1159 (2002) Fourth Edition Insect Control Equipment - Electrocution Type
- UL 1244 (2000) Fourth Edition Electrical & Electronic Measuring & Testing Equipment
- UL 1261 (2001) Fifth Edition Electric Water Heaters for Pools and Tubs
- UL 1262 (1990) Third Edition Laboratory Equipment
- UL 1411 (1998) Fifth Edition Transformers for Use in Audio, Radio & TV Type Receivers
- UL 1459 (1995) Third Edition Telephone Equipment
- UL 1594 (2001) Third Edition Sewing and Cutting Machines
- UL 1638 (2001) Fourth Edition Visual Signaling Appliances - Private Mode Emergency and General Utility Signaling
- UL 1876 (2001) Third Edition Isolating Signal and Feedback Transformers for Use in Electronic Equipment
- UL 60950 (2000) Third Edition Safety of Information Technology Equipment (Replaces UL 1950)
- UL 61010A-1 (2002) First Edition Electrical Equipment for Laboratory Use PART 1: General Requirements (Replaces 1301-1)
- UL RCD (1995) UL Recognized Component Director

* Partial Listing

Typical Test Values for Product Safety Tests**

No.	Product Category	Test Voltage* (V)	Max Current (A)	Test Time (sec)	Test Current (A)	V Limit (V)	R Max (Ω)	Test Time (sec)
UL 1950	IT Equipment	1500V AC 2121V DC	No arc-over or breakdown	60	25	12V AC or DC	0.1	60
CSA C22.2 No. 950	IT Equipment	1500V AC 2121V DC	"	60	30	12V AC or DC	0.1	12
EN 60950	IT Equipment	1500V AC 2121V DC	"	60	25	12V AC or DC	0.1	12
UL 2601-1	Medical Equipment	1500V AC 2121V DC	"	60	25	6V AC	0.1	5
CSA C22.2 No. 601-1	Medical Equipment	1500V AC 2121V DC	"	60	25	6V AC	0.1	5
EN 60601-1	Medical Equipment	1500V AC 2121V DC	"	60	25	6V AC	0.1	5
UL 544	Medical Equipment	V ≥ 240V: 1000 +2V	"	60	25	6V AC	0.1	5
		V < 240V: 1000 +2.4V	"	1	25	6V AC	0.1	5
CSA C22.2 No. 125	Medical Equipment	1000V AC 1414V DC	"	60	30	12V AC or DC	0.1	12
UL 1492	Audio-Video Equipment	1080V AC 1530V DC	"	1	20	12V AC	0.1	
CSA C22.2 No. 1	Audio-Video Equipment	1000V AC 1414V DC	"	1	30	12V AC or DC	0.1	12
EN 60065	Audio-Video Equipment	2120V peak	"	60	--	--	--	
CAN CSA E65-94	Audio-Video Equipment	2120V peak	"	60	20	12V AC	0.1	
UL 6500	Audio-Video Equipment	2120V peak	"	60	--	--	--	
UL 3101-1	Laboratory Equipment	1350V AC 1900V DC	"	60	25	12V AC or DC	0.1	60
UL 3111-1	Test & Meas. Equipment	1350V AC 1900V DC	"	60	25	12V AC or DC	0.1	60
CSA C22.2 No. 1010.1	Lab, Control, Test & Meas. Equipment	1350V AC 1900V DC	"	60	25	12V AC or DC	0.1	60
EN 61010-1	Lab, Control, Test & Meas. Equipment	1350V AC 1900V DC	"	60	25	12V AC or DC	0.1	60
CSA C22.2 No. 14	Industrial Control	1000V +2x max rated V	"	60	30	12V AC or DC	0.1	60
EN 60335-1	Household Appliances	1000V AC	"	60	25	12V AC or DC	0.1	60

* Test Voltage for products rated up to 250V AC.

** Partial Listing, Check Standard and Governing/Certifying Agency for specific requirements.

Typical Test Values for Product Safety Tests**

No.	Product Category	Test Voltage* (V)	Max Current (A)	Test Time (sec)	Test Current (A)	V Limit (V)	R Max (Ω)	Test Time (sec)
UL 982	Motor Operated Household Food Preparation Machines	for ≤ 1/2hp 1000V AC	No arc-over or breakdown	60	--	--	--	--
		1200V AC	"	1				
		for > 1/2hp 1000V AC + 2(rated V)	"	60				
		1200V AC + 2.4(rated V)	"	1				
		2250V AC Electric knives or wand mixers	"	60				
		2500V AC	"	1				
CSA C22.2 No. 195	Motor Operated Food Processing Appliances	1000V AC	"	60	30	12V AC or DC	0.1	12
CSA C22.2 No. 64	Household Cooking & Liquid Heating Appliances	1000V AC	"	60	30		0.1	12
CSA C22.2 No. 71.1	Portable Electric Tools	1000V AC + 2(rated V)	"	60	30		0.1	12
UL 1004	Electric Motors	for ≤ 1/2hp 1000V AC	"	60	--		--	
		1200V AC	"	1				
		for > 1/2hp 1000V AC + 2(rated V)	"	60				
		1200V AC + 2.4(rated V)	"	1				
UL 1026	Electric Household Cooking & Food Serving Appliances	1000V	"	60	Production-line ground continuity check required			
		1200V	"	1				
UL 1017 (Bi-National Standard: US/Canada)	Vacuum Cleaners & Blower Cleaners	for ≤ 1/2hp 1000V AC	"	60	Production-line ground continuity check required			
		1200V AC	"	1				
		for > 1/2hp 1000V AC + 2(rated V)	"	60				
		1200V AC + 2.4(rated V)	"	1				

* Test Voltage for products rated up to 250V AC.

** Partial Listing, Check Standard and Governing/Certifying Agency for specific requirements.

Application Note Directory

QuadTech Application Notes

Contained herein is a list of QuadTech application notes, current as of the published date of this version of the EST Reference Guide. These notes are all available for download in Adobe PDF format. To access these application notes visit: <http://www.quadtech.com/resources> and click on the Application Note link. In the table below, the application note (AN) numbers highlighted in blue contain information relevant to EST topics.

A/N P/N	Title/Description	Release
035000	Measuring Insulation Resistance of Capacitors	10-10-00
035001	Series & Parallel Impedance Parameters and Equivalent Circuits	06-29-00
035002	Equivalent Series Resistance (ESR) of Capacitors	09-28-00
035003	Increasing Test Voltage on the QuadTech Digibridge	10-10-00
035004	High Voltage DC Bias on the QuadTech Digibridge	10-10-00
035005	Application for Precision Impedance Meters in a Standards Laboratory	10-10-00
035006	Application for Precision Impedance Meters in a Standards Laboratory	07-18-00
035008	Application of DSP to Precision LCR Measurements	08-17-00
035009	Measuring Biased Inductors with the 7000 Precision LCR Meters	11-08-00
035010	A Guide to LCR Measurements	06-23-00
035011	A Practical Guide to Dielectric Testing	06-23-00
035012	Measurements of Dielectric Constant and Loss with the LD-3 Cell	02-11-02
035019	Helpful Tips on Measuring Capacitors	06-27-00
035020	Testing Capacitors with the QuadTech Model 1865 Megohmmeter/IR Tester	11-08-00
035021	What's Changing in Appliance Hipot Testing and Why	11-08-00
035022	Measuring Biased Inductors with the QuadTech Digibridge	11-08-00
035023	Characteristic Cable Impedance	11-20-00
035024	Calibrating Impedance Meters Using Resistance Standards	08-18-00
035025	Advanced Technique for Dielectric Analysis	11-20-00
035026	Medical Equipment Test Applications using the 7000 Precision LCR Meter	09-28-00
035027	Multi-Terminal Impedance Measurements (Why do these bridges use so...)	10-05-01
035028	Testing Automotive Engine Oxygen Sensors using the 1900 Precision LCR	02-11-02
035029	Hipot Testing of Motors and Safety Standard Compliance	12-19-00
035030	Transformer Turns Ratio using the 7000 Series RLC Meters	12-19-00
035031	The QuadTech 1865 as a Current Meter	12-19-00
035032	Measuring Large Capacitors with the 1865-52 Component Test Fixture	12-19-00
035033	Insulation Resistance of Cables	09-28-00
035034	1865 Remote Pass/Fail Lights	01-08-01
035035	1865 Specified Accuracy	01-08-01
035036	The QuadTech 1865 Averaging	01-08-01
035037	How to Connect a Foot Switch to the 1870 Dielectric Analyzer	01-08-01
035038	The 1880 Specified Accuracy & Constant Current Ranges	01-10-01
035039	External DC Supply for the 1536 Photoelectric Pickoff Cell	01-10-01
035040	Basic Program to Control the Flash on a 1539 Strobe	01-10-01
035041	Characteristic Cable Impedance	01-10-01
035042	Constant Current with the 1693 RLC Digibridge	05-26-00
035043	Charged Capacitor Protection Circuit for the QuadTech Digibridges	02-15-02
035044	Transformer Ratio Measured Directly on the 1689 & 1693 Digibridges	01-15-01
035045	How Much is One Joule	07-05-00
035046	7000 Series Connections to the LD-3 Dielectric Cell	01-15-01
035047	Digibridge Connections to the LD-3 Dielectric Cell	01-15-01
035048	Battery Impedance Measurements	07-18-00
035049	Charged Capacitor Protection for the 7000	02-13-01
035050	What Voltage and Current is Applied to the Unknown?	08-18-00
035051	Power Factor of a Capacitor (1900 Series)	02-01-02
035052	Tutorial on Safety Standard Compliance for Hipot Testing	06-27-00
035053	Benefits and Advantages of Digital Electrical Safety Testers	02-13-01
035054	Measuring Electrical Properties of Copier/Printer Toners	02-13-01
035055	Monitoring the Production Process of Tantalum Powder	02-28-01
035056	Transducers used in Monitoring Nuclear Waste Tanks	02-28-01
035057	Measuring the Dielectric Constant of PVC Compounds	02-28-01
035058	Testing Animal Identification Implants	02-28-01

QuadTech Application Notes

A/N P/N	Title/Description	Release
035059	Testing Telecommunications Transformers	02-28-01
035060	Enhanced Protection When Measuring Charged Capacitors	02-28-01
035061	Light Ballast Application	09-28-00
035062	Cable Reel IR Testing Application	03-27-01
035063	Adhesive Heat-Shrink IR Testing	03-27-01
035064	Why Perform Electrical Safety Testing?	08-17-00
035065	Ground Bond, Ground Continuity and Earth Continuity	08-17-00
035066	Appliance Testing with the Guardian 6200 Production Safety Analyzer	03-27-01
035067	Determining if a DUT is connected, using the Low Trip Limit (G1000 Series)	02-04-02
035068	UL Standards	03-27-01
035069	Guidelines for External Bias on the 7400 and 7600	04-24-01
035070	Digibridge to 7000 Handler Conversion	04-24-01
035071	Increasing Test Voltage of a 7000 Series RLC Meter	04-24-01
035072	Mutual Inductance Measurements with a 4-Terminal LCR Meter	08-18-00
035073	Connection of the 1865 Megohmmeter to a Resistivity Cell	04-24-01
035074	Guardian 5000 Demo Guide	07-18-00
035075	Guardian 2500 Demo Guide	07-31-00
035076	Sentry 10-35 Demo Guide	07-18-00
035077	Sentry 50 Demo Guide	07-31-00
035078	Glossary of Electrical Safety Terms	01-16-02
035079	Digibridge and Battery Impedance Measurements (1557, 1659, 1689, 1693)	05-16-00
035080	Use of Palm Switches with QuadTech Hipot Testers	05-09-00
035082	Analyze This Inductor	02-11-02
035083	So You Need To Measure Some Inductors...	06-04-01
035084	LCR Product Accessories	05-05-00
035085	EST Product Accessories	05-05-00
035086	What's Your LCR IQ?	10-05-01
035087	Applying DC Bias to Inductors with the 1910 Inductance Analyzer	05-19-00
035088	Applying DC Bias to Inductors with the 1910 and 1320	06-15-00
035089	LCR & EST Product Interfaces	06-15-00
035090	Electrical Safety Testing of Medical Electronic Equipment	06-16-00
035091	Ensuring RH Sensor Repeatability with Capacitance Testing	06-16-00
035092	Measuring IR with the Guardian 2530	07-05-00
035093	Errors in Low Resistance Measurements	07-31-00
035094	Building the Perfect Component Test Fixture	09-26-00
035095	Custom Design Your Own Shock Therapy	09-26-00
035096	Test Instrumentation: Can't Always Get What You Want?	11-28-00
035097	Guardian 2500 Series Features & Benefits	01-23-01
035098	Sentry Series Features & Benefits	01-23-01
035099	Overview of IEC 60601-1 Medical Electrical Equipment	05-08-01
035100	Why Product Safety Test Your Electrical Medical Products?	05-08-01
035101	Line Leakage Measurement & Human Body Equivalent Circuits	06-08-01
035102	IEC60601-1 and Your Electrical Medical Products	08-08-01
035103	A Bridge to the Future... Capacitance Measurements Through The Ages	10-05-01
035104	What is the Accuracy Anyway?	10-12-01
035105	25 Patents Reference Digibridge	10-15-01
035106	Henry Hall: Father of the Digibridge	10-15-01
035107	1920 Used in Eddy Current Sensor Testing	10-16-01
035108	1689 Digibridge Used In Gas Sensor Materials Testing	10-17-01
035109	Classification per IEC60601-1	10-22-01
035110	EST 101 (IEC60601-1 Electrical Safety Tests)	01-29-02
035111	Ensuring the Safety of Medical Electronics	02-01-02
035112	Low ESR Capacitor Measurements	02-11-02
035113	Measurement of Dielectric Constant and Loss: 1900 LCR Meter & LD-3 Cell	02-11-02
035114	1900 Series Remote I/O Handler	03-11-02
035115	Resistive Load Boxes for Hipot Testers and Megohmmeters	03-12-02
035116	Guardian 6000 Series Scanner Connections	03-29-02
035117	Leakage Current – Part 1	05-__-02
035118	Leakage Current – Part 2	06-__-02

Glossary

AC

Alternating current, an electric current that has one polarity during part of the cycle and the opposing polarity during the other part of the cycle. Residential electricity is AC.

Applied Part

Part of the medical product that in normal use comes in contact with the patient. They are often referred to as patient connections. There are three types of applied parts; B, BF and CF. They are classified based upon usage: C being cardiac versus non-cardiac and F being floating/isolated from earth ground.

ANSI

American National Standards Institute, an industry association that defines standards for data processing and communication.

Arcing

Sparking or "flashing over" caused by a breakdown of electrical insulation.

Basic Insulation

Insulation providing basic protection against electrical shock.

Breakdown

Failure of electrical insulation to provide a dielectric barrier to current flow.

Capacitance

The ratio of charge on either plate of a capacitor to the potential difference (voltage) across the plates. When a voltage is applied, current flows immediately at a high rate and then decays exponentially toward zero as the charge builds up. If an ac voltage is applied, an ac current appears to flow continuously because the polarity of the voltage is reversed at the frequency of the applied voltage. The waveform of this current, however, is displaced in time from the applied voltage by 90°.

Charging Current

An insulated product exhibits the basic characteristics of a capacitor. Application of a voltage across the insulation causes a current to flow as the capacitor charges. This current instantaneously rises to a high value as voltage is applied then exponentially decays to zero as the DUT becomes fully charged. Charging current decays to zero much faster than dielectric absorption.

Class I Product

Product that use Basic Insulation in combination with an additional safety level of using Protective Earth. Class I products have a three prong power cord.

Class II Product

Product that relies not only on basic insulation but an additional safety level of supplemental Insulation or Reinforced insulation. Class 2 products typically have a two-prong power cord.

Clearance

Clearance is the shortest distance between two conductors through air or insulating medium.

Creepage

Creepage is the shortest path along the surface of an insulator or insulating medium that separates two conductors. The insulator or insulation medium cannot be air.

CSA

Canadian Standards Association.

Current Draw

The mains current consumed by the product or DUT.

DC

Direct current, non-reversing polarity. The movement of charge is in one direction. Used to describe both current and voltage. Batteries supply direct current.

Delay Time

The amount of time an instrument waits before performing a task.

Dielectric Absorption

The physical phenomenon in which insulation appears to absorb and retain an electrical charge slowly over time. Apply a voltage to a capacitor for an extended period of time and then quickly discharge it to zero voltage. Leave the capacitor open circuited for a period of time then connect a voltmeter to it and measure the residual voltage. The residual voltage is caused by the dielectric absorption of the capacitor.

Dielectric Strength

The Dielectric Strength of a material is the ratio between the voltage at which breakdown of the insulating material occurs and the distance between the two points subject to the applied voltage.

Dielectric Withstand Test

A high voltage either AC or DC is applied to determine if a breakdown will occur in the insulation of the DUT. Also referred to as a HIPOT test or Dielectric Withstand test.

Discharge

The act of draining off an electrical charge to ground. Devices that retain charge should be discharged after a DC hipot or IR test.

Double Insulated

A descriptive term indicating that a product is designed so that a single ground fault cannot cause a dangerous voltage to be applied to any exposed part of the product that a user might touch.

Double Insulation

Insulation comprising of both Basic Insulation and Supplemental Insulation.

DUT

Device Under Test - the product being tested.

Dwell Time

The amount of time the DUT is allowed to stabilize at the test voltage before measurements are performed.

Earth Leakage Current

The leakage current from all earthed parts of the product. The current flowing from the mains supply through or across insulation into the Protective Earth Conductor.

Electric Current

The flow of electrons (or electron "holes") through a conducting material, which may be a solid, liquid, or gas; the rate of flow of charge past a given point in an electric circuit. The magnitude of current flow through the conductor is proportional to the magnitude of voltage or electrical potential applied across the conductor and inversely proportional to the resistance (or impedance) of the conductor. Current is expressed in amperes or milliamperes (amperes/1000).

Fall Time

The amount of time it takes to gradually decrease the voltage to zero potential.

Frequency

The rate at which a current or voltage reverses polarity and then back again completing a full cycle, measured in Hertz (Hz) or cycles per second.

GFCI

An acronym for Ground Fault Circuit Interrupter, a safety device that breaks a power circuit as soon as it detects current flow of a certain magnitude through the ground return of a power circuit. Also known as GFI.

Ground

The base reference from which voltages are measured, nominally the same potential as the earth. Also the side of a circuit that is at the same potential as the base reference.

Ground Bond Test

Verifies that all conductive parts of a product that are exposed to user contact are connected to the power line ground. The GB test verifies the integrity of the ground connection using a high current AC signal (as high as 30Amps). GB provides a better simulation of how a product will perform under an actual fault condition.

Ground Continuity Test

A test to verify that all conductive parts of a product that are exposed to user contact are connected to the power line ground. GC Test normally performed with a low current DC signal that checks to ensure the ground connection has a resistance of $<1 \Omega$.

Hertz

The unit of measure of frequency, equivalent to cycles per second.

High Limit

The upper value for a test to be considered a PASS. If the measured value is higher than the high limit the test is considered a FAIL. In hipot, leakage current and ground bond tests a high limit is required.

Hipot Tester

An instrument for testing dielectric strength using a high potential (voltage); hence, the term "hipot".

IEEE

An acronym for Institute of Electrical and Electronic Engineers, a professional association of engineers.

IEEE 488

General Purpose Interface Bus (GPIB) - an industry standard definition of a parallel bus connection for the purpose of communicating data between devices.

Impedance

A term used with alternating current circuits to describe the "ac resistance" to the flow of current through a circuit when an ac voltage is applied across the terminals of that circuit. Impedance is a complex quantity composed of real (in phase with voltage) and reactive (out of phase by 90°) components. Impedance is calculated as voltage divided by current.

Insulation

The protection against unwanted flow of current through a path, as between a circuit of a product and the ground reference. Materials that prevent current flow are referred to as insulators or dielectrics.

Insulation Resistance

Characteristic of an insulating material that being subject to voltage, indicates a resistance such that the value of leakage current which flows through it stays within acceptable limits.

Interlock

A device or arrangement by means of which the functioning of one part is controlled by the functioning of another, for safety purposes.

Kelvin Connection

A circuit configuration that automatically compensates for measurement errors caused by resistance of leads between a tester and the point of measurement on a DUT.

Leakage Current

The residual flow of current through insulation after a high voltage has been applied for a period of time.

Load

The total resistance or impedance of all circuits and devices connected to a voltage source.

Low Limit

The lower value for a test to be considered a PASS. If the measured value is lower than the low limit the test is considered a FAIL. In insulation resistance mode a low limit is required.

Megohmmeter

An instrument designed to measure high values of resistance using a dc voltage usually greater than 50 V DC.

Milliohmmeter

An instrument designed to measure low values of resistance using a dc current or voltage.

Mode

The test that is to be performed such as AC Hipot (WAC), DC Hipot (WDC), Insulation Resistance (IR), Ground Bond (GR) or Leakage Current (LC).

NIST

National Institute of Standards and Technology, an agency of the U.S. Government that sets standards for physical measurements and references, formerly called the National Bureau of Standards.

NRTL

Acronym for Nationally Recognized Testing Laboratory, such as Underwriters Laboratories (UL), Factory Mutual (FM), or Canadian Standards Association (CSA).

Offset

An automatic zeroing function to correct for leakage currents or additional resistance due to test leads or fixtures. An offset is performed by making a measurement at the programmed test settings, calculating the difference between the leakage current or resistance measured and the ideal current or resistance and then subtracting this difference from all future measurements.

Ohm's Law

The fundamental law of electrical circuits that describes the relationship between voltage, current and impedance (or resistance). For DC circuits, Ohm's Law states that $\text{Current} = \text{Voltage} / \text{Resistance}$. For AC circuits, $\text{Current} = \text{Voltage} / \text{Impedance}$. Stated conversely, $\text{Voltage} = \text{Current} \times \text{Resistance}$ (DC) or $\text{Current} \times \text{Impedance}$ (AC). The difference between the dc resistance and ac impedance is that ac circuits must deal with phase and time relationships and dc circuits do not.

Ohms (Ω)

The unit of measure of resistance and impedance, derived from Ohm's Law.

OSHA

Occupational Safety and Hazards Administration, an agency of the U.S. Government that regulates industrial safety.

Patient Auxiliary Current

Current flowing between patient connections and that is not intended to be there to produce an effect in the patient.

Patient Leakage Current

The current flowing from every individual part of the applied part back to earth or the current flowing from an unintended appearance of a voltage on the patient back to an F-Type Applied Part.

Phase

The time relationships between alternating voltages, currents, and impedances. Usually expressed as complex vectors with "real" (in-phase) and "reactive" (out of phase) components.

Polarization

A term used to describe a "one way" limitation on the insertion of a plug into a receptacle for a corded product. A polarized plug can be inserted in only one orientation and cannot be reversed.

Potential

Electrical potential is a term equivalent to "voltage".

Prefixes

The prefixes for Multiple Scientific Engineering Symbols are:

1000000000000000	10 ¹⁵	Peta	P
1000000000000	10 ¹²	Tera	T
1000000000	10 ⁹	Giga	G
1000000	10 ⁶	Mega	M
1000	10 ³	Kilo	k
0.001	10 ⁻³	milli	m
0.000001	10 ⁻⁶	micro	μ
0.000000001	10 ⁻⁹	nano	n
0.0000000000001	10 ⁻¹²	pico	p
0.000000000000001	10 ⁻¹⁵	femto	f

Protective Earth

Conductor that connects between any protectively earthed parts of a Class I product and an external protective earth connection.

Microsecond

One millionth of a second.

Ramp Time

The gradual increase of voltage from zero potential over a period of time (step).

Reactive

The component of an ac voltage, current, or impedance that is 90° out of phase with the "real" or in phase component. Reactive components are associated with capacitive or inductive circuits.

Real

The component of an ac voltage, current, or impedance that is in phase with the "real" component. Real components are associated with purely resistive circuits.

Regulation

When applied to electrical circuits, regulation refers to the variation in output voltage that occurs when the input voltage changes or when the connected load changes. When applied to test laboratories and agencies, refers to the control exercised by these entities over test specs and rules.

Reinforced Insulation

A single system of insulation that provides two levels of protection against electrical shock.

Resistance

The electrical characteristic that impedes the flow of current through a circuit to which voltage has been applied. Resistance is calculated by Ohm's Law as voltage divided by current (for DC circuits). For AC circuits, it is the in-phase or "real" component of impedance. Units are expressed in ohms (Ω).

RS232

An industry standard definition for a serial line communication link or port.

Scanner

A scanner is a device designed to switch or matrix signals.

Signal Input/Output Part (SIP/SOP)

Part of the medical product that is not an Applied Part but is intended to send or receive signals from other external equipment.

Single Fault Condition

Condition in which a single means of electrical safety protection is defective or an abnormal condition is present. Examples of a single fault condition would be interruption of the ground conductor on a Class I product or opening of the neutral supply conductor to the product.

SCC

The Standards Council of Canada, an agency of the Canadian Government analogous to OSHA in the United States.

Spikes

A large momentary deviation from a normal voltage or current waveform.

Stabilization Time

The time required for a transient disturbance to decay to a steady state value.

Step

Most electrical safety testers can perform tests in a sequence. The step number indicates in which order the tests will be performed. For example if step 1 is a ground bond test, step 2 an AC hipot and step 3 an insulation resistance measurement then when a test is started the electrical safety tester will perform a ground bond test followed by an AC hipot then an insulation resistance measurement.

Supplemental Insulation

Independent insulation applied in addition to Basic Insulation in order to provide protection against electrical shock in the event of a failure of Basic Insulation.

Touch/Chassis Leakage (Enclosure)

Leakage Current from the enclosure or other parts, excluding applied parts that are not connected to a protective earth conductor.

Type Test

A one-time test intended to verify adequacy of the design of a product to meet a safety standard.

UL

Underwriters Laboratories, Inc., an NRTL located in Illinois.

Voltage

The electrical potential applied to a circuit.

Waveform

The instantaneous value of a variable such as voltage or current plotted against time.

X (Reactance)

Reactance is the imaginary component of Impedance.

Y (Admittance)

Admittance is the reciprocal of Impedance. $Y = 1/Z$

Z (Impedance)

Impedance is the sum of alternating current oppositions (capacitive reactance, inductive reactance and resistance). $Z = R + jX$

QuadTech is a trademark of QuadTech, Inc.
Digibridge is a registered trademark of QuadTech, Inc.
Copyright 2002 by QuadTech, Inc.
4th Edition, May 2002, P/N 030120/A4
All rights reserved
Printed in U.S.A.